

**TOSHIBA**

FILE NO. 050-200122

SERVICE MANUAL

PLASMA DISPLAY MONITOR

***50WP16A, 50WP16C***  
***50WP16H, 50WP16R***  
***50WP16EA, 50HP81***

If you need more information on Computer and Electronic Repair, please visit these websites to improve yourself.

<http://www.fastrepairguide.com>

<http://www.protech2u.com>

<http://www.plasma-television-repair.com>

<http://www.lcd-television-repair.com>

Happy Repairing!!

### **Highly Recommended Repair Ebook:**

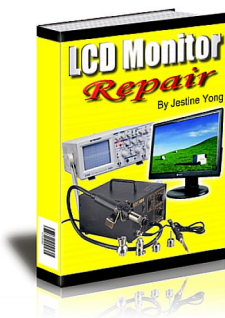

If you're a LCD Monitor repairer, then this is the best guide for you. Why? Because, the author revealed all his LCD Monitor Repairing secrets for you. I think, with just few Repair tips you learned from this guide you will get back your investment!

[Click Here to read](#) more.



This eBook will show you how to test the electronic component correctly and accurately. Some of you may say that I don't need this eBook because it is too simple! Do you know that, in fact there is lots of testing electronic components secrets I have learned from this guide? Do you know how to test a 'TRIAC' correctly and accurately? If you answer no then I guess you have to get this eBook. [Click Here to read more.](#)

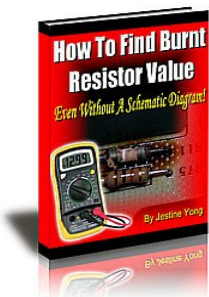

Are you tired of searching the service manuals to look for the value of a burnt resistor? If the answer is YES, then this eBook is a 'must have' guide for you. You can save a lot of time and be able to repair customer's Electronic equipment with burnt resistors in it.

[Click here to read more.](#)

# 13 Block and Schematic Diagrams

## 13.1. Schematic Diagram Notes

### Important Safety Notice

Components identified by  $\Delta$  mark have special characteristics important for safety. When replacing any of these components, use only manufacture's specified parts.

#### Notes:

##### 1. Resistor

All resistors are carbon 1/4W resistor, unless marked as follows:

Unit of resistance is OHM [ $\Omega$ ] (K=1,000, M=1,000,000).

- |                  |                 |
|------------------|-----------------|
| ○ : Nonflammable | ⊠ : Metal Oxide |
| △ : Solid        | ◎ : Metal Film  |
| ⊞ : Wire Wound   | ⊗ : Fuse        |

##### 2. Capacitor

All capacitors are ceramic 50V capacitor, unless marked as follows:

Unit of capacitance is  $\mu$ F, unless otherwise noted.

- |                              |                     |
|------------------------------|---------------------|
| ⊗ : Temperature Compensation | ⊕-⊖ : Electrolytic  |
| Ⓜ : Polyester                | Ⓜ : Bipolar         |
| Ⓜ : Metalized Polyester      | Ⓜ : Dipped Tantalum |
| ⊞ : Polypropylene            | Ⓜ : Z-Type          |

##### 3. Coil

Unit of inductance is  $\mu$ H, unless otherwise noted.

##### 4. Test Point

- : Test Point position

##### 5. Earth Symbol

- |                          |                      |
|--------------------------|----------------------|
| ⏏ : Chassis Earth (Cold) | ⏏ : Line Earth (Hot) |
|--------------------------|----------------------|

##### 6. Voltage Measurement

Voltage is measured by a DC voltmeter.

Conditions of the measurement are the following:

- |                               |  |
|-------------------------------|--|
| Power Source .....            | AC 220V-240V, 50/60Hz<br>(A, B and E Version)          |
| Receiving Signal .....        | AC 120V, 50/60Hz (U Version)<br>Colour Bar signal (RF) |
| All customer's controls ..... | Maximum positions                                      |

##### 7. Number in red circle indicates waveform number.

(See waveform pattern table.)

##### 8. When arrow mark (↗) is found, connection is easily found from the direction of arrow

##### 9. Indicates the major signal flow.      : Video ➡      Audio ⇄

##### 10. This schematic diagram is the latest at the time of printing and subject to change without

#### Remarks:

1. The Power Circuit contains a circuit area which uses a separate power supply to isolate the earth connection.  
The circuit is defined by HOT and COLD indications in the schematic diagram. Take the following precautions.  
All circuits, except the Power Circuit, are cold.  
Precautions
  - a. Do not touch the hot part or the hot and cold parts at the same time or you may be shocked.
  - b. Do not short-circuit the hot and cold circuits or a fuse may blow and parts may break.
  - c. Do not connect an instrument, such as an oscilloscope, to the hot and cold circuits simultaneously or a fuse may blow.  
Connect the earth of instruments to the earth connection of the circuit being measured.
  - d. Make sure to disconnect the power plug before removing the chassis.
2. Following diodes are interchangeable.  
MA150- MA162 (Replacement part)

### 13.2. Main Block Diagram

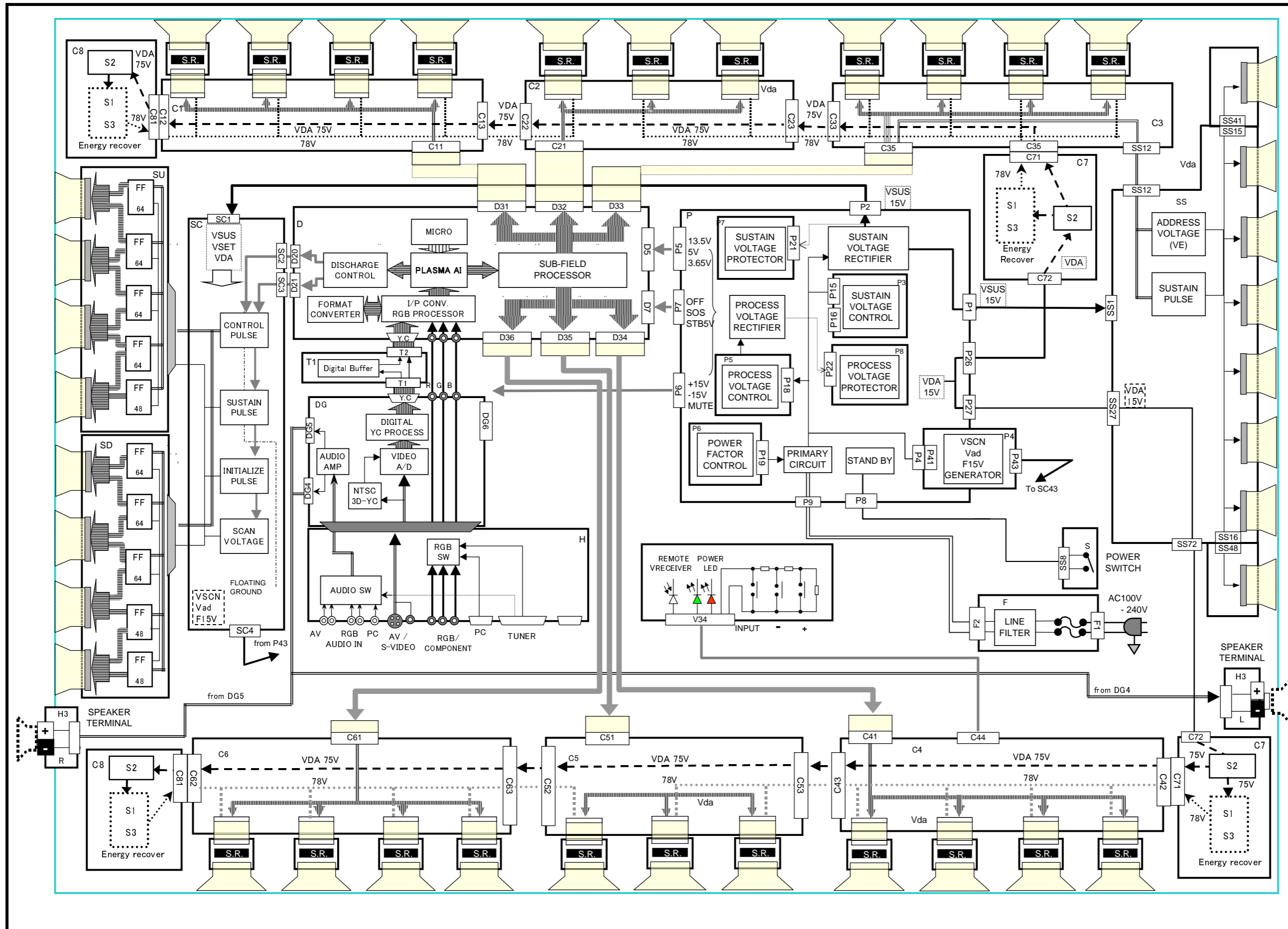

### 13.3. Power (F, P1, P3, P4, P5, P6, P7, P8 and P9 Board) Block Diagram

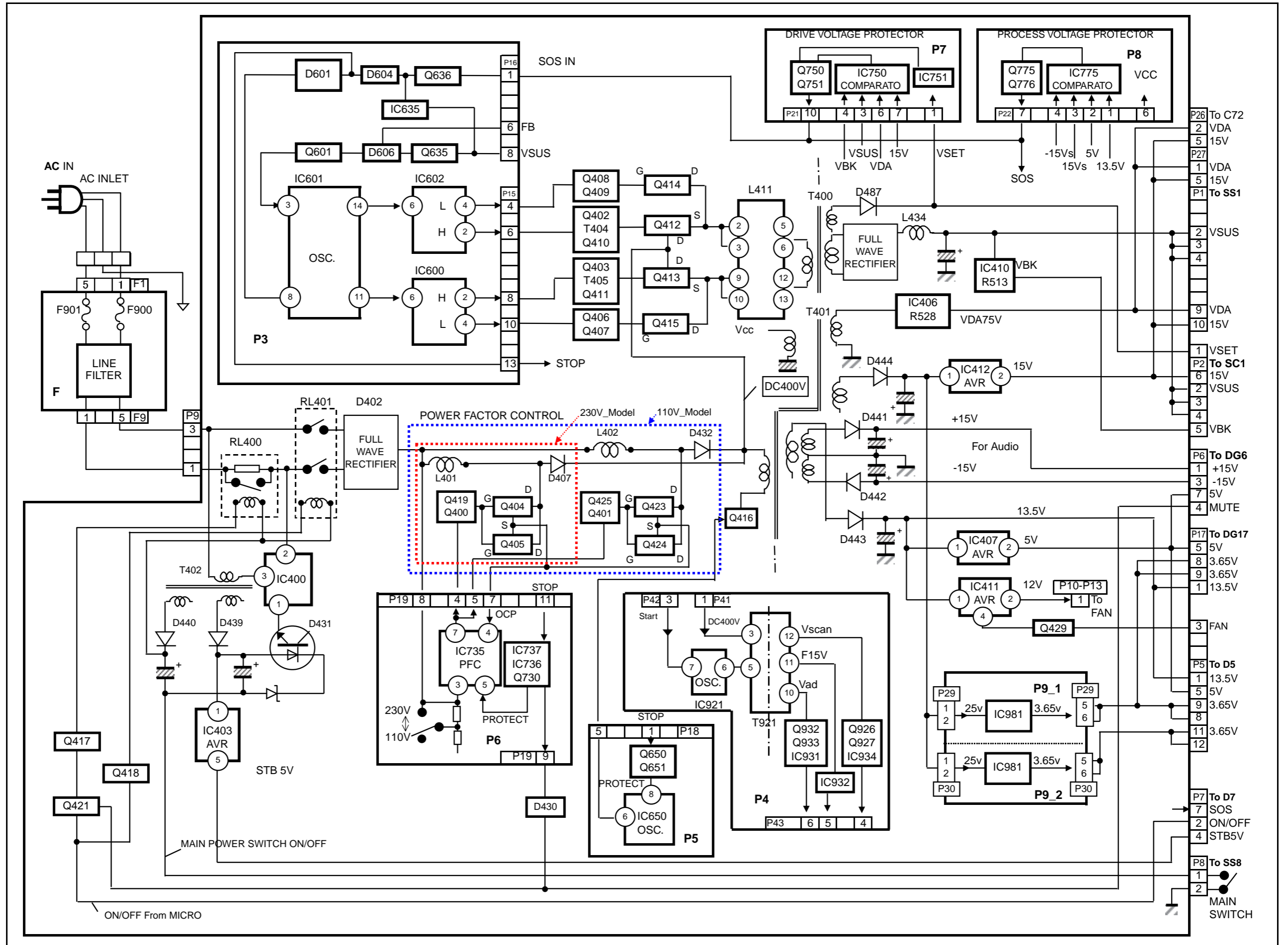

# 13.4. P1-Board (1/2) Schematic Diagram

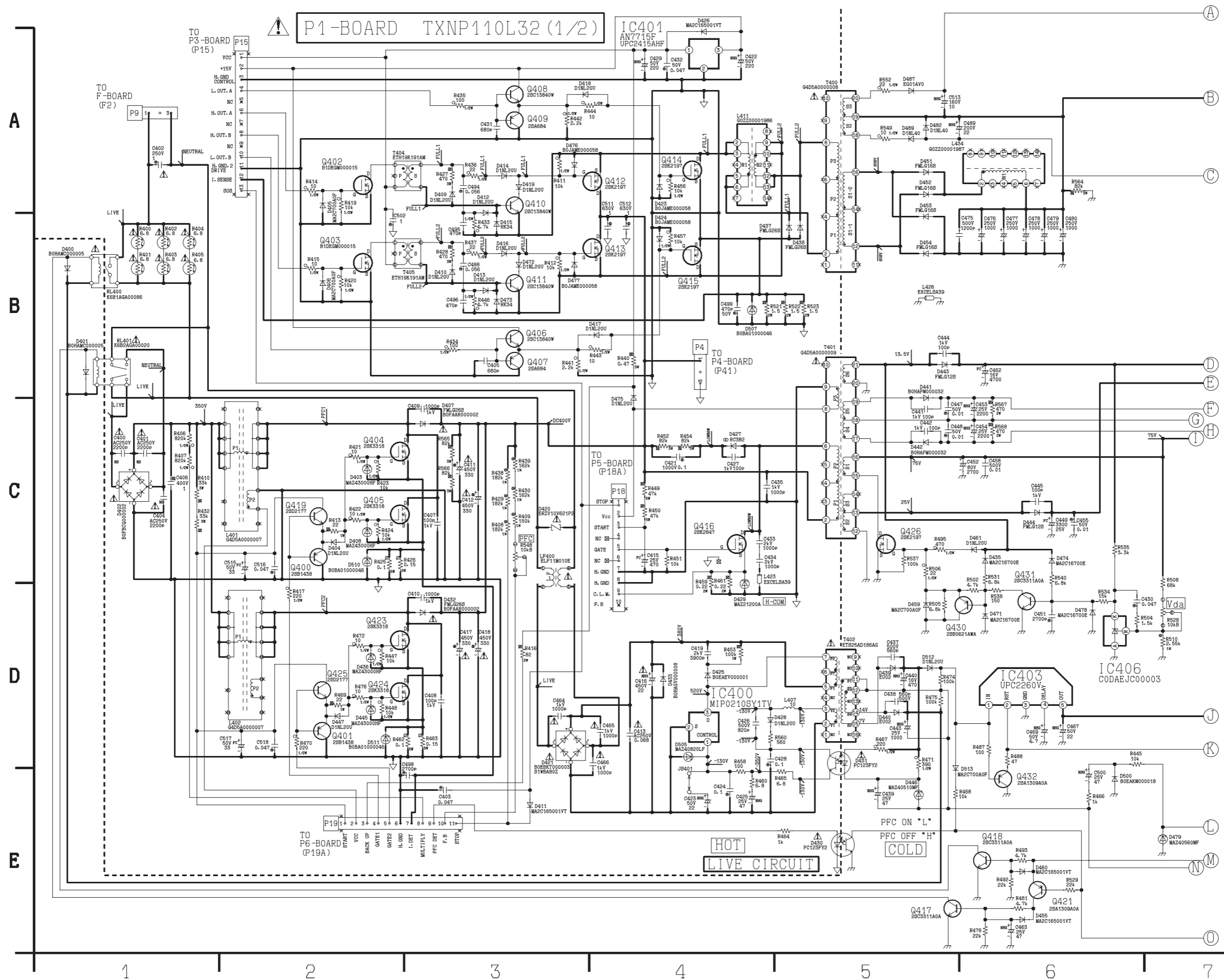

# 13.5. P1-Board (2/2) Schematic Diagram

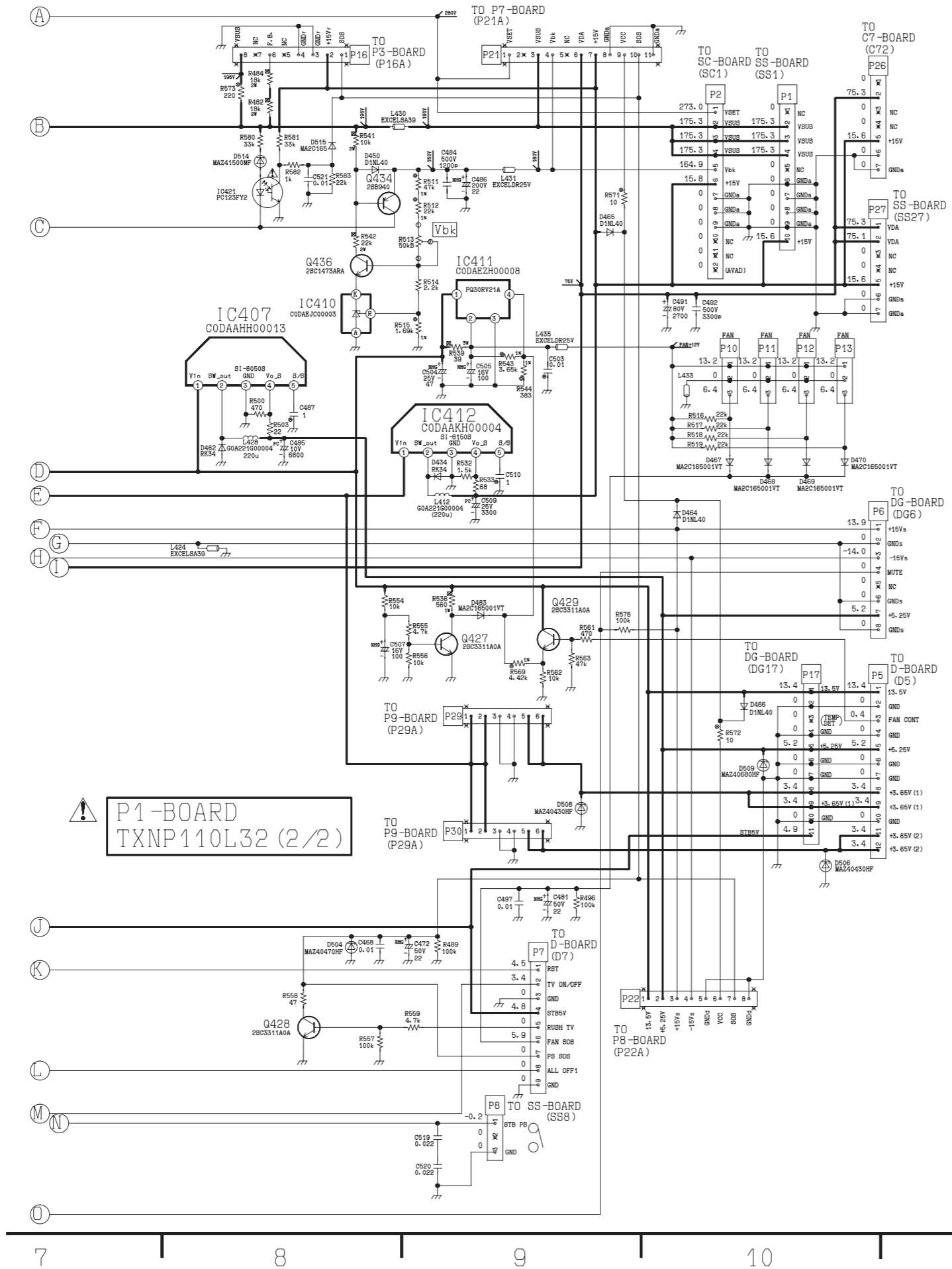

### 13.6. P3 and P4-Board Schematic Diagram

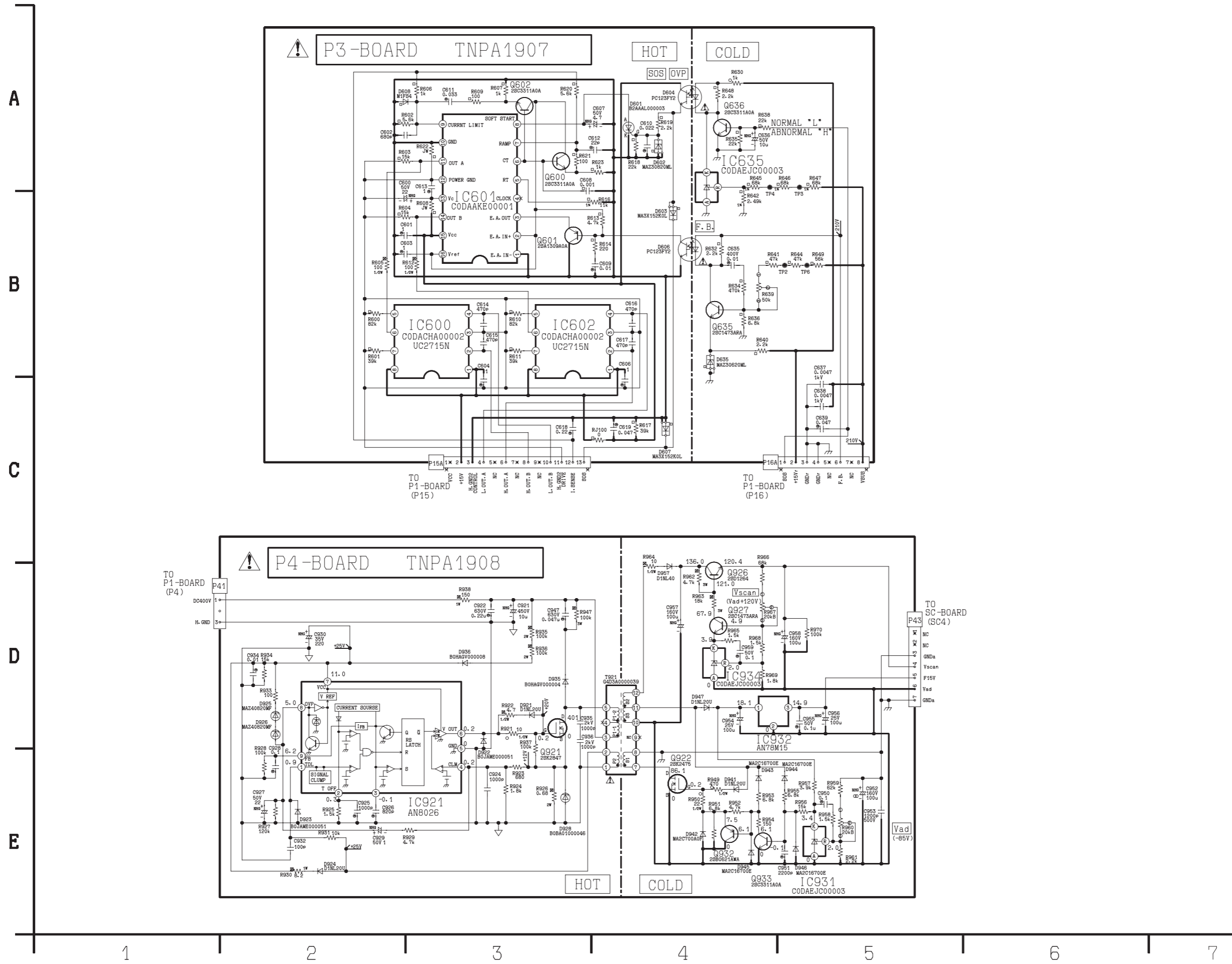



### 13.7. P5, P6, P7 and P8-Board Schematic Diagram

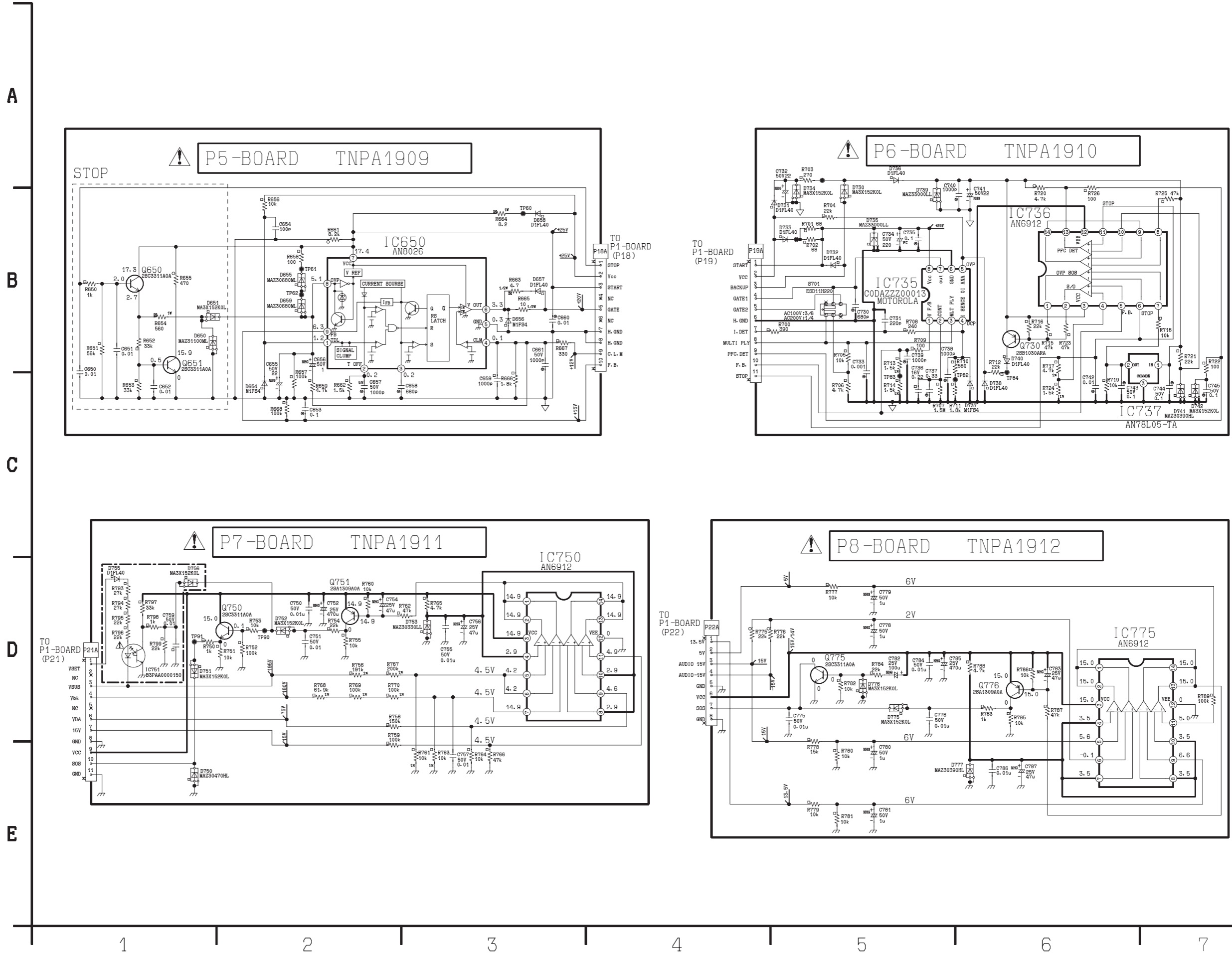

### 13.8. P9 and F-Board Schematic Diagram

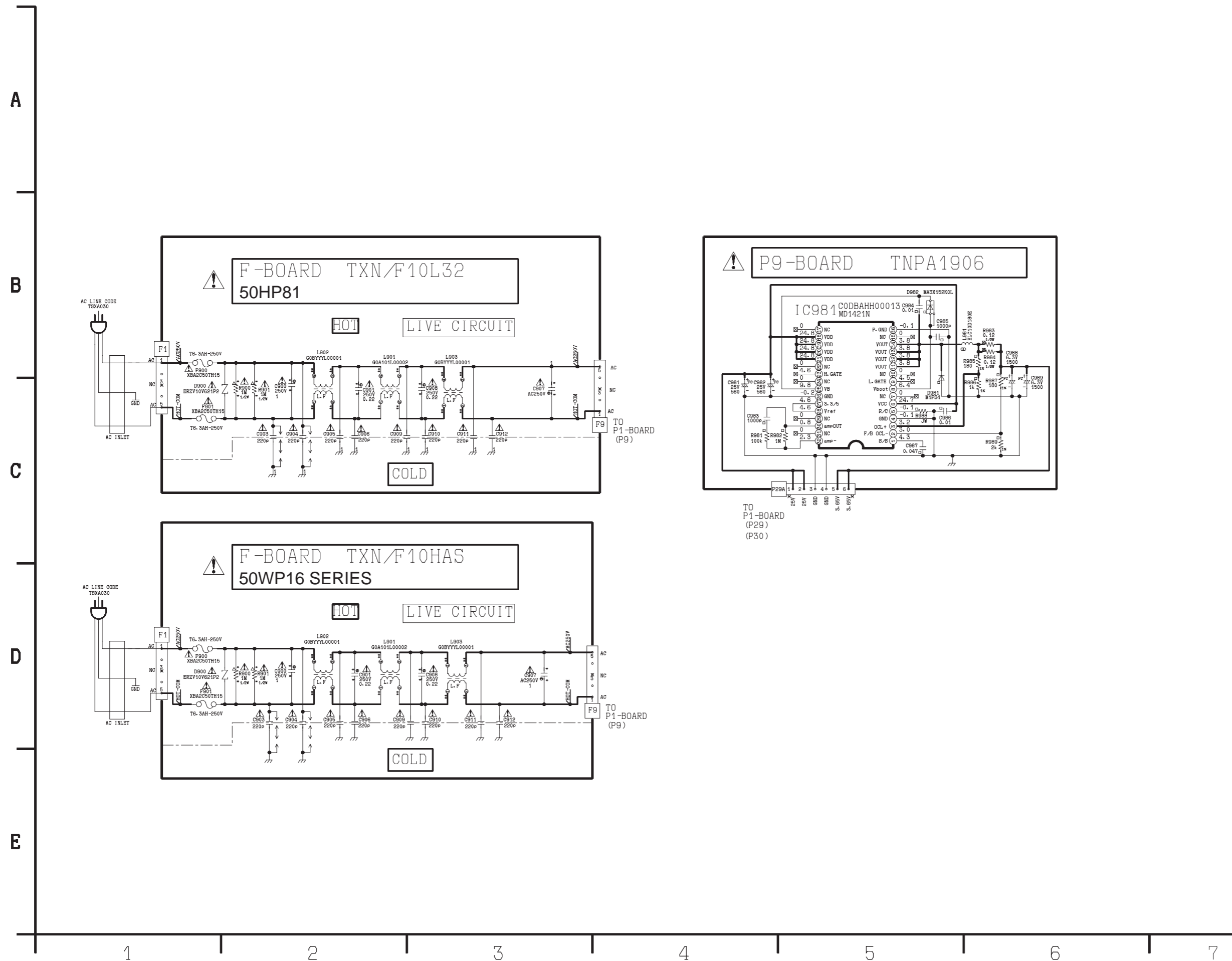

### 13.9. H-Board Block Diagram

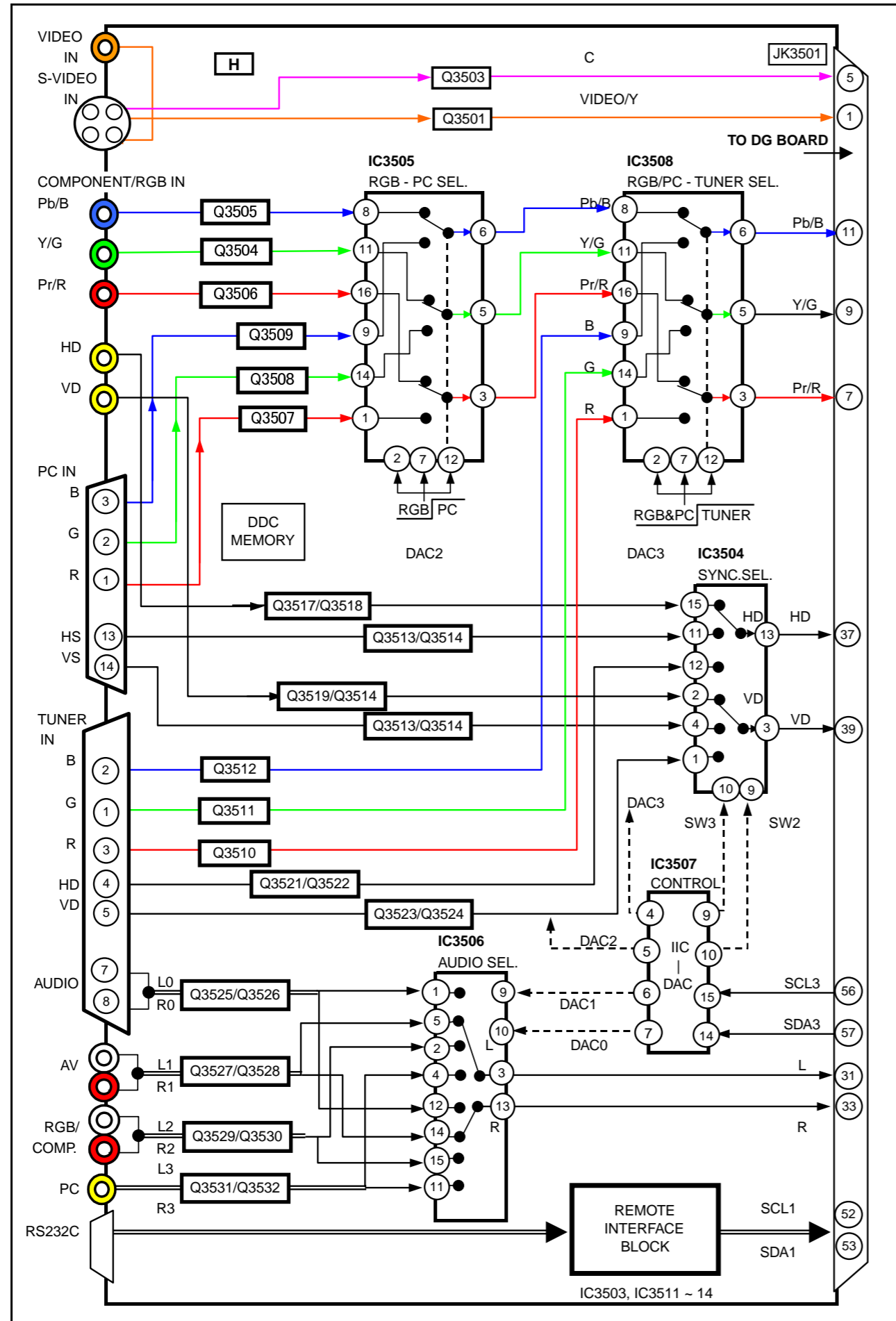

# 13.10. H-Board (1/4) Schematic Diagram

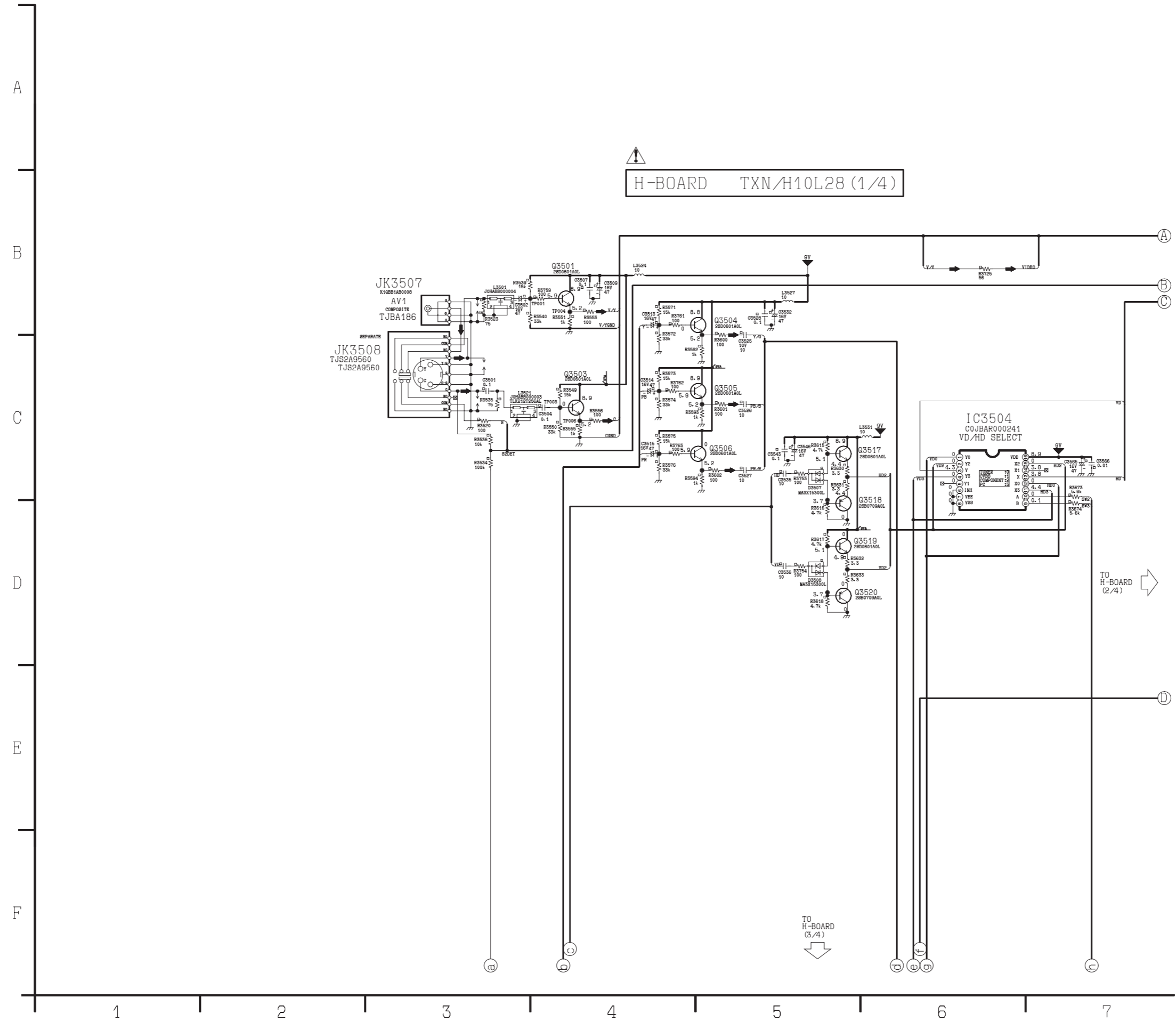

# 13.11. H-Board (2/4) Schematic Diagram

⚠  
H-BOARD TXN/H10L28 (2/4)

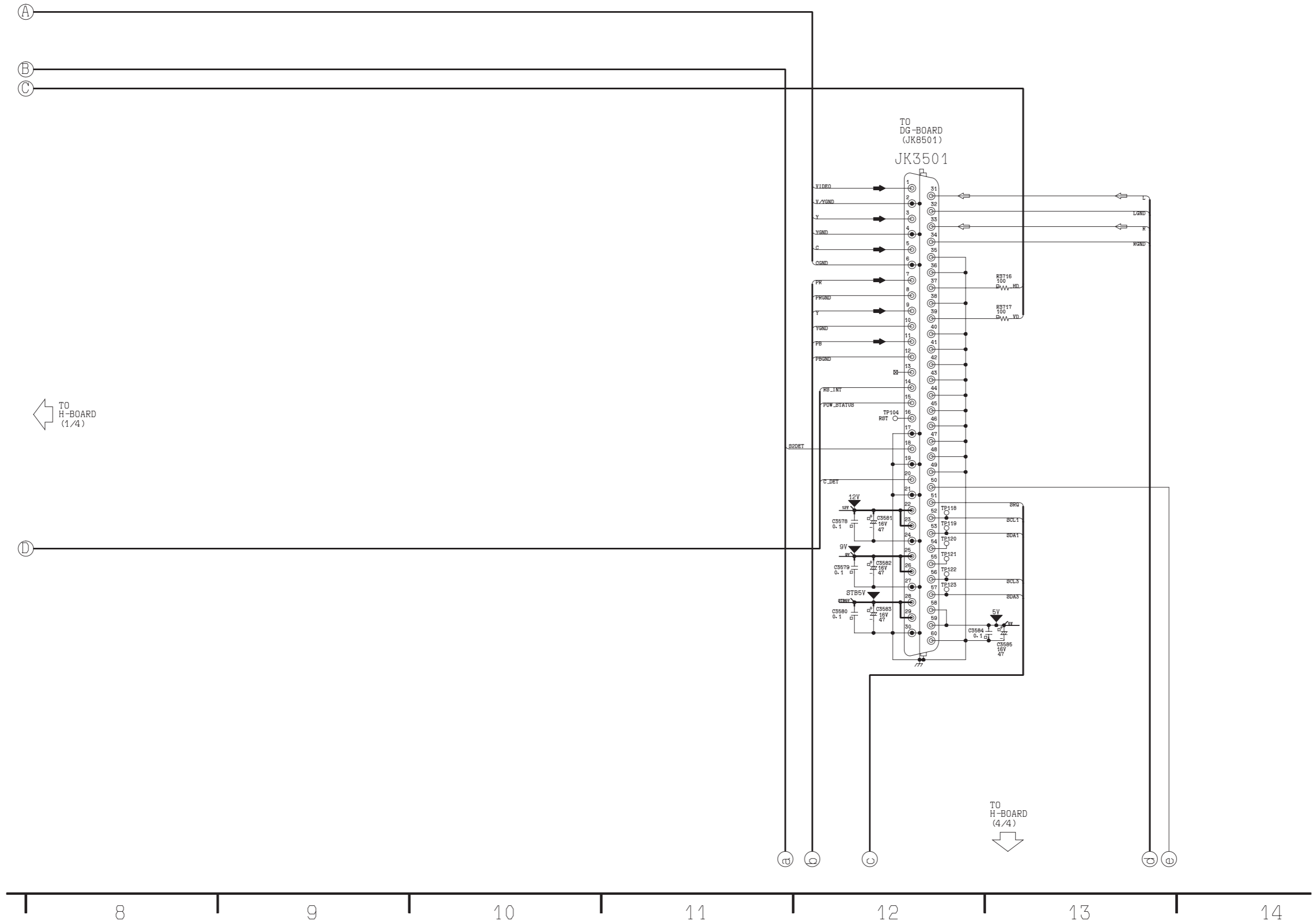

### 13.12. H-Board (3/4) Schematic Diagram

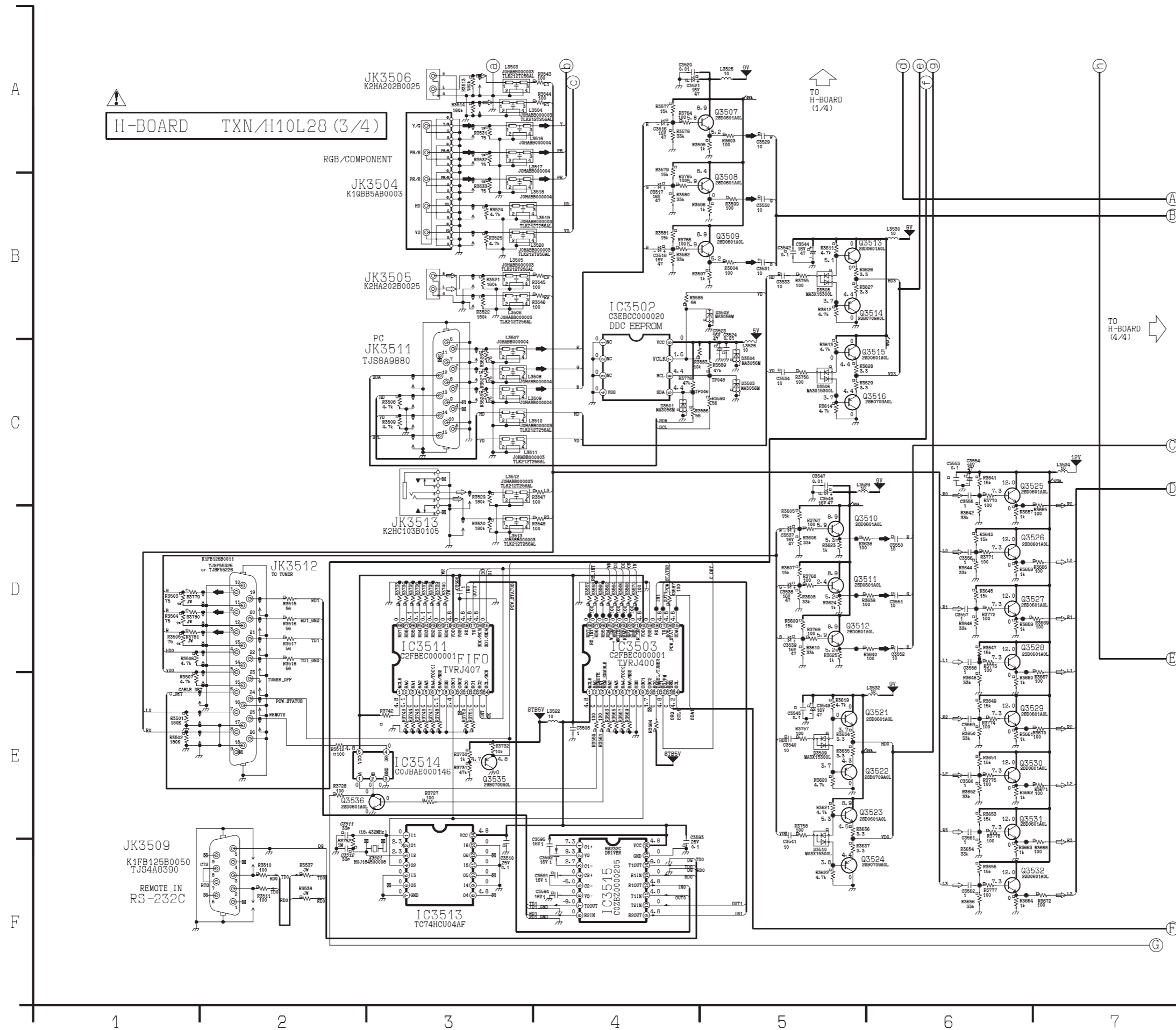

# 13.13. H-Board (4/4) Schematic Diagram

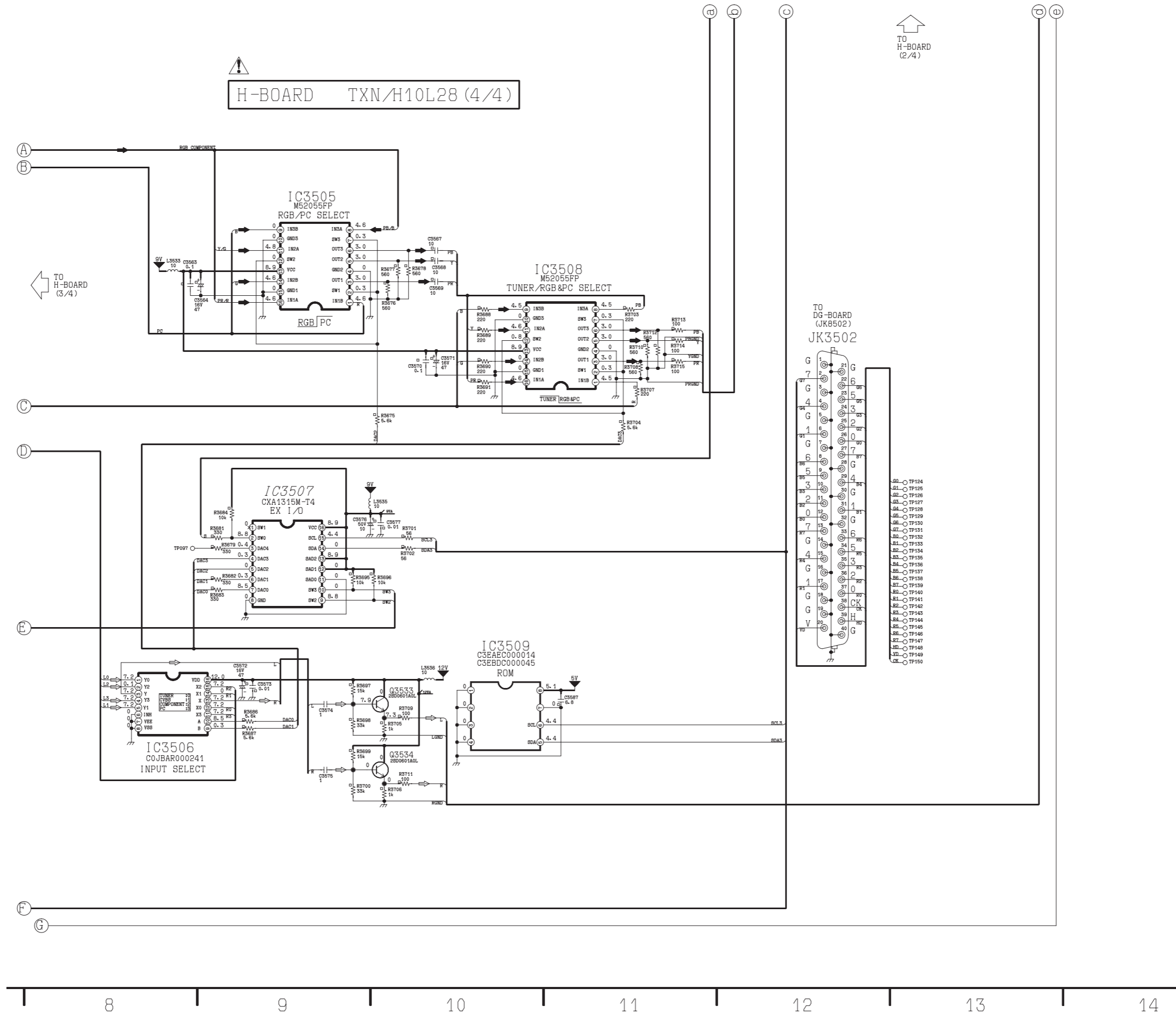

### 13.14. DG Board Block Diagram

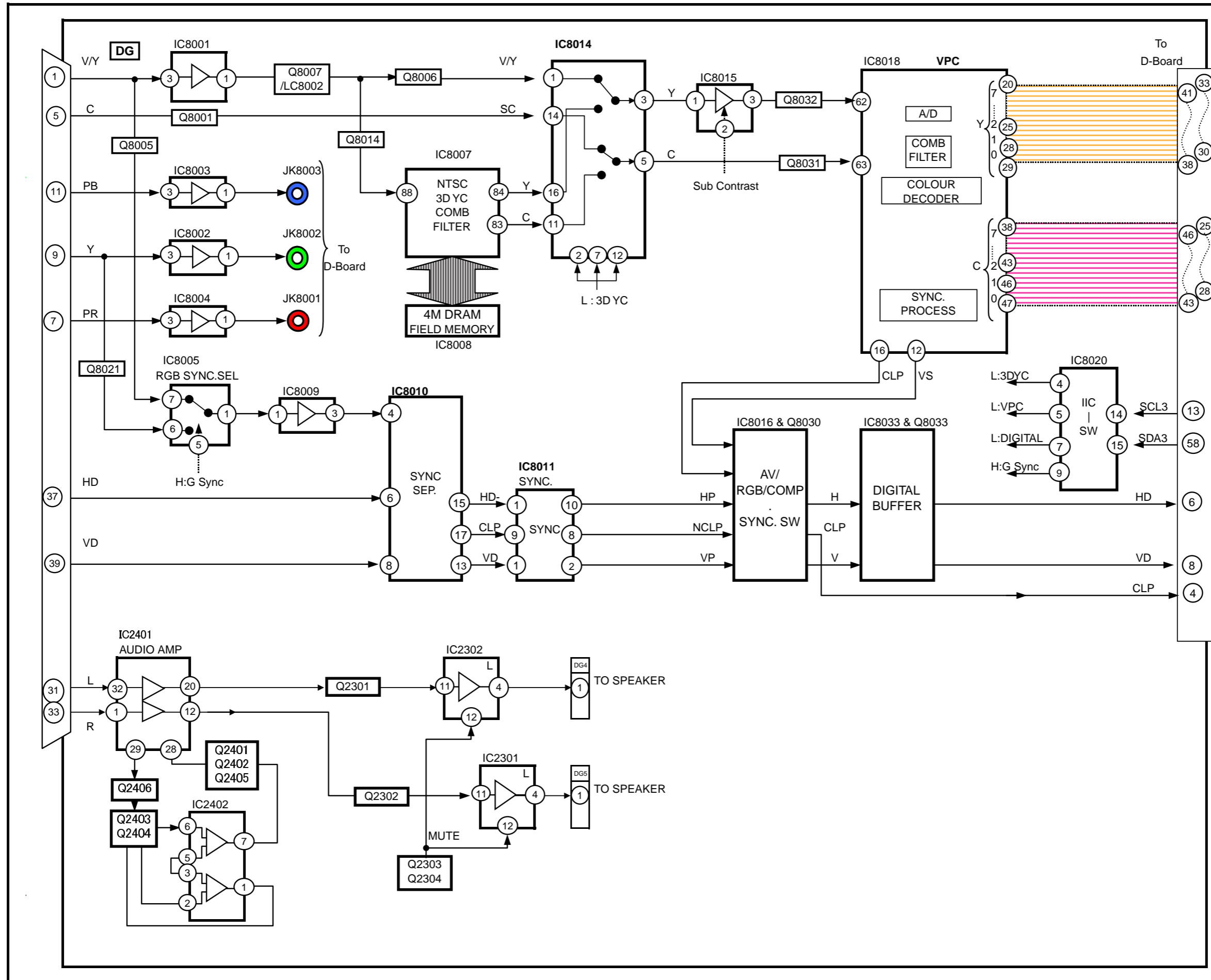



# 13.15. DG-Board (1/4) Schematic Diagram

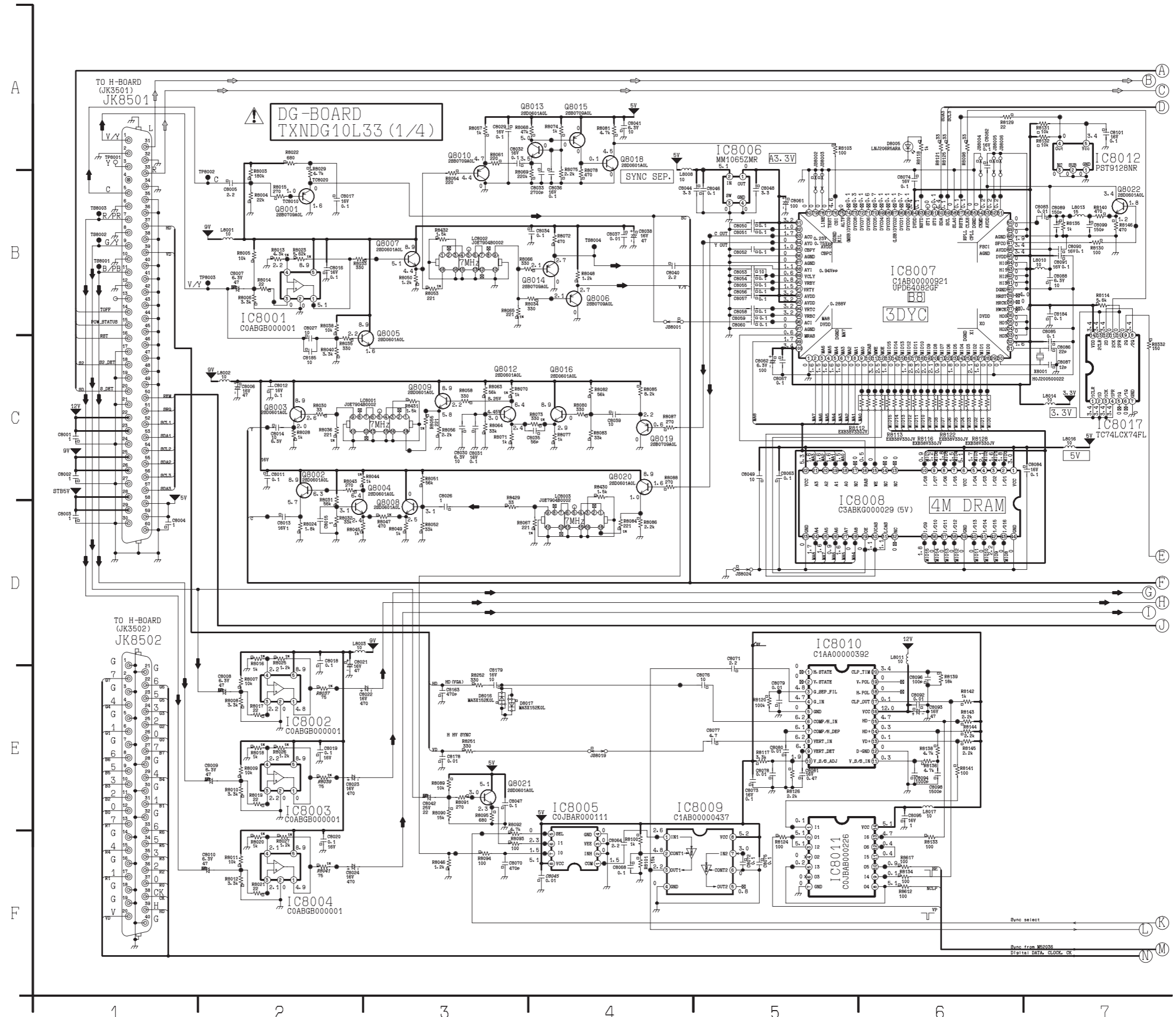



# 13.17. DG-Board (3/4) Schematic Diagram

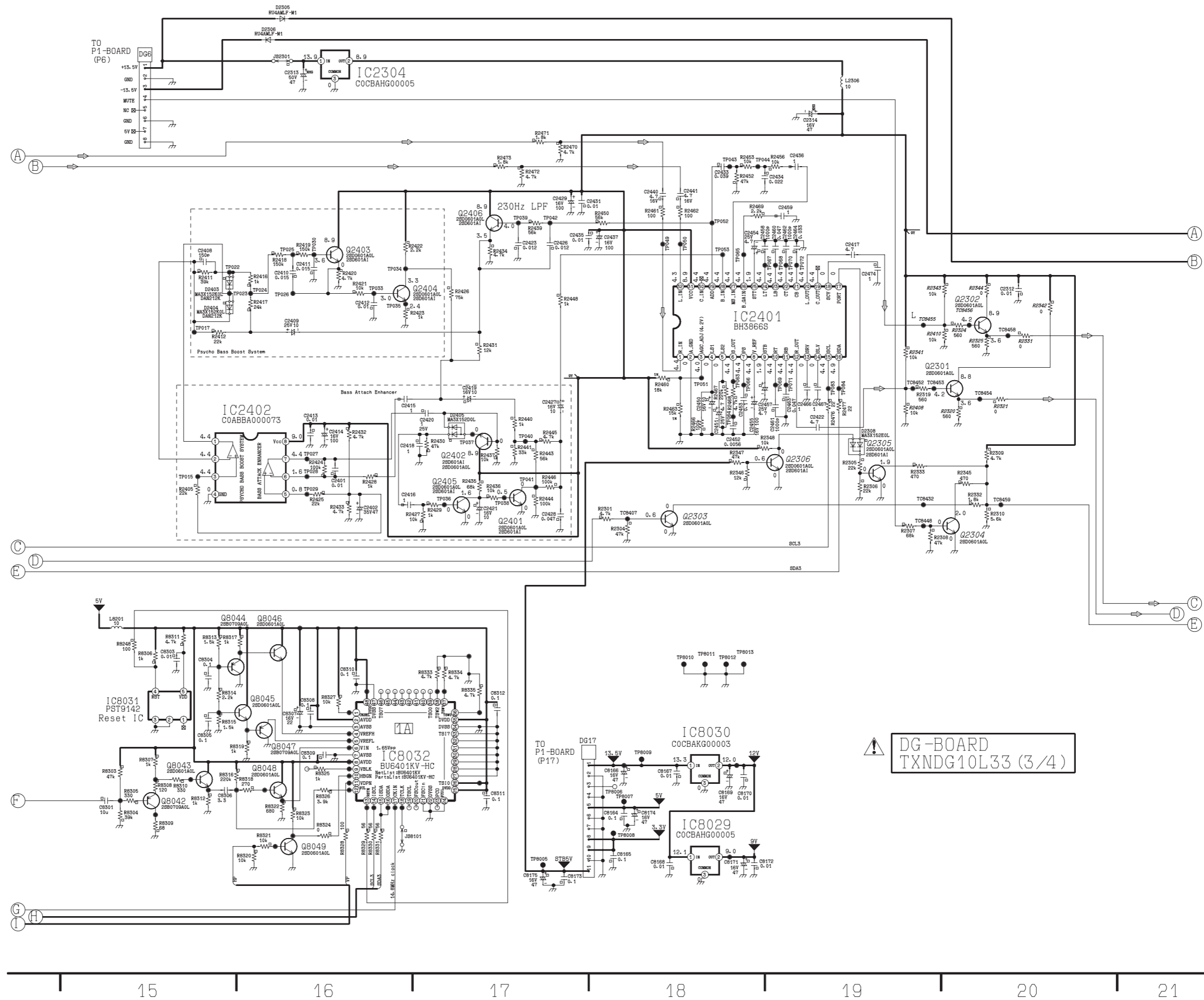

### 13.18. DG-Board (4/4) Schematic Diagram

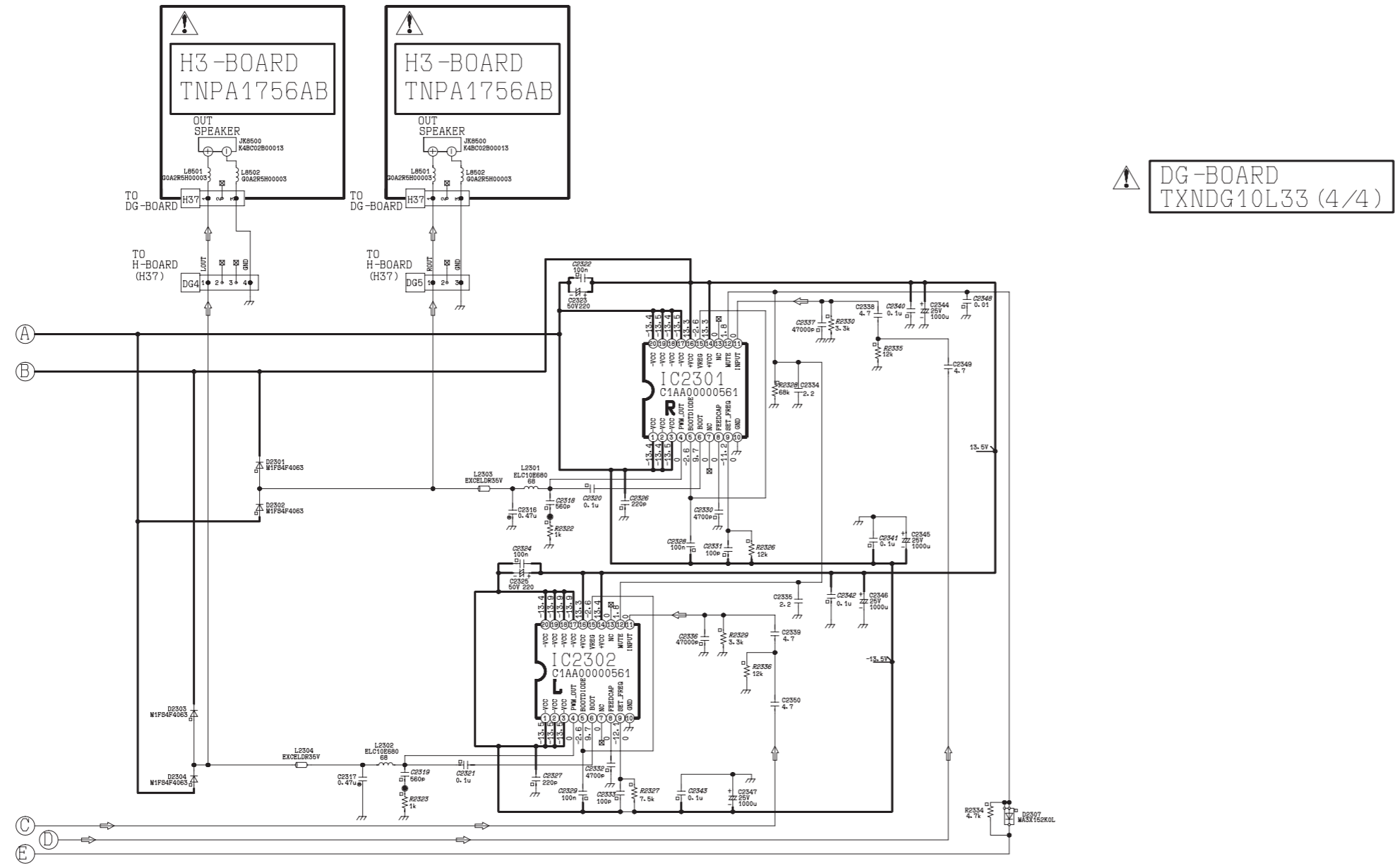

13.19. T11 Board Schematic Diagram

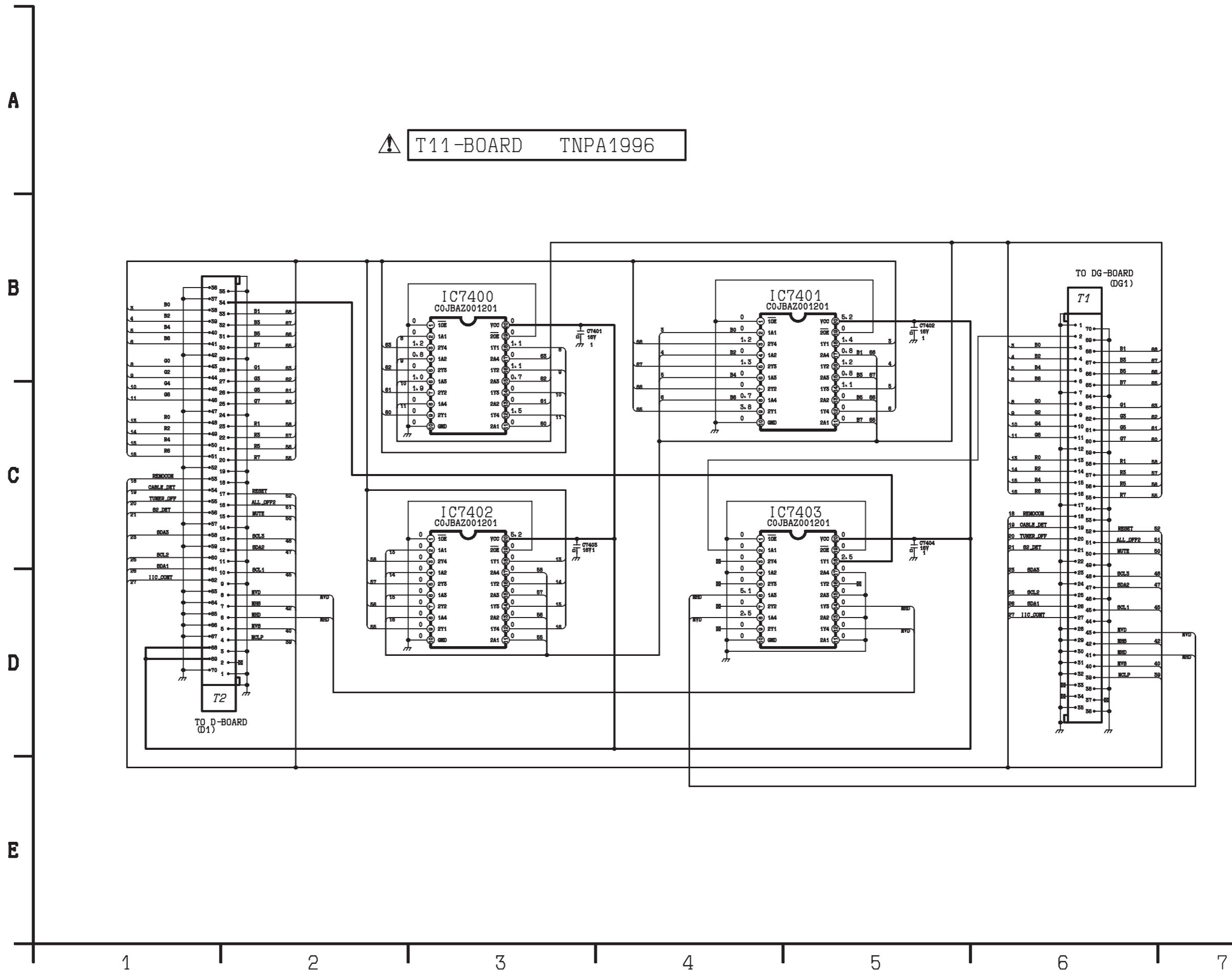

### 13.20. D-Board IC Location

IC No.	*/36	Page
IC9000	1	95
IC9001	1	95
IC9002	13	107
IC9003	1	95
IC9004	1	95
IC9005	1	95
IC9006	13	107
IC9007	2	96
IC9008	2	96
IC9009	2	96
IC9010	1	95
IC9012	13	107
IC9014	4	98
IC9015	25	119
IC9016	25	119
IC9017	25	119
IC9018	2	96
IC9019	1	95
IC9020	1	95
IC9021	1	95
IC9022	1	95
IC9023	1	95
IC9024	28	122
IC9036	16	110
IC9047	5	99
IC9048	29	123
IC9061	7	101
IC9093	4	98
IC9200	3	97
IC9201	3	97
IC9202	3	97
IC9204	4	98
IC9206	16	110
IC9207	4	98
IC9209	4	98
IC9210	16	110
IC9211	4	98
IC9211	4	98
IC9212	4	98
IC9213	4	98
IC9214	4	98
IC9215	4	98
IC9217	4	98
IC9223	15	109
IC9225	5	99
IC9226	29	123
IC9250	27	121
IC9251	27	121
IC9254	28	122
IC9259	28	122
IC9302	5	99
IC9352	29	123
IC9400	6	100
IC9401	6	100
IC9401	6	100
IC9402	6	100
IC9403	6	100
IC9450	30	124
IC9451	30	124
IC9452	30	124
IC9453	30	124
IC9501	22	116

IC No.	*/36	Page
IC9502	23	117
IC9503	10	104
IC9504	11	105
IC9505	35	129
IC9506	34	128
IC9507	23	117
IC9508	23	117
IC9509	23	117
IC9510	23	117
IC9511	23	117
IC9512	24	118
IC9513	24	118
IC9516	21	115
IC9520	10	104
IC9521	34	128
IC9551	19	113
IC9552	8	102
IC9554	8	102
IC9555	32	126
IC9557	20	114
IC9558	8	102
IC9559	20	114
IC9560	8	102
IC9561	20	114
IC9562	21	115
IC9563	21	115
IC9564	21	115
IC9565	21	115
IC9701	26	120
IC9702	26	120
IC9703	26	120
IC9704	27	121
IC9705	27	121
IC9706	26	120
IC9707	27	121
IC9900	2	96
IC9901	3	97
IC9902	3	97
IC9903	3	97
IC9904	3	97
IC9905	3	97
IC9906	3	97
IC9907	3	97
IC9908	2	96
IC9909	2	96

# 13.21. D-Board Information (1/4)

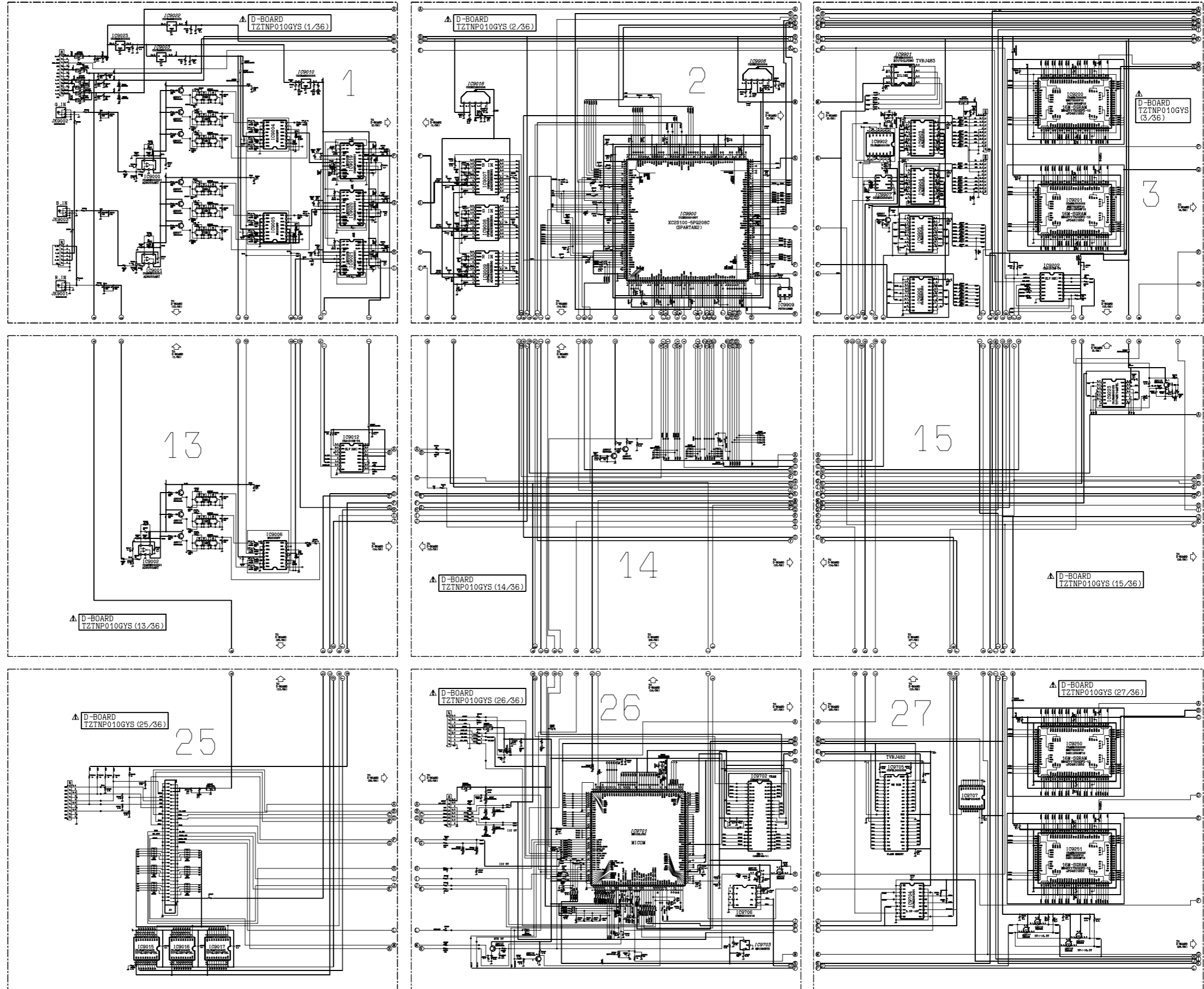

### 13.22. D-Board Information (2/4)

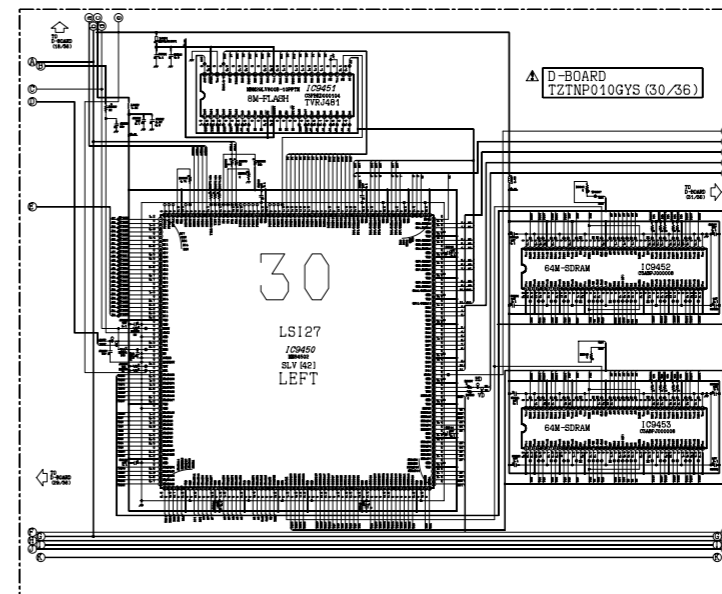
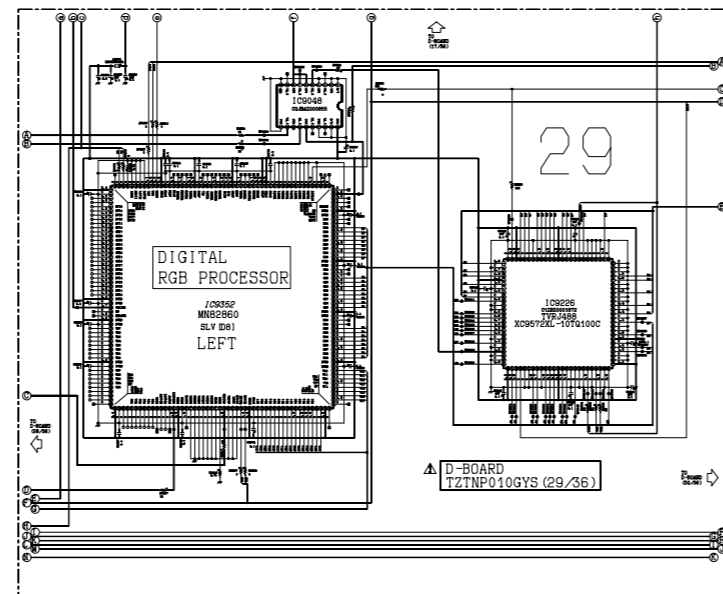
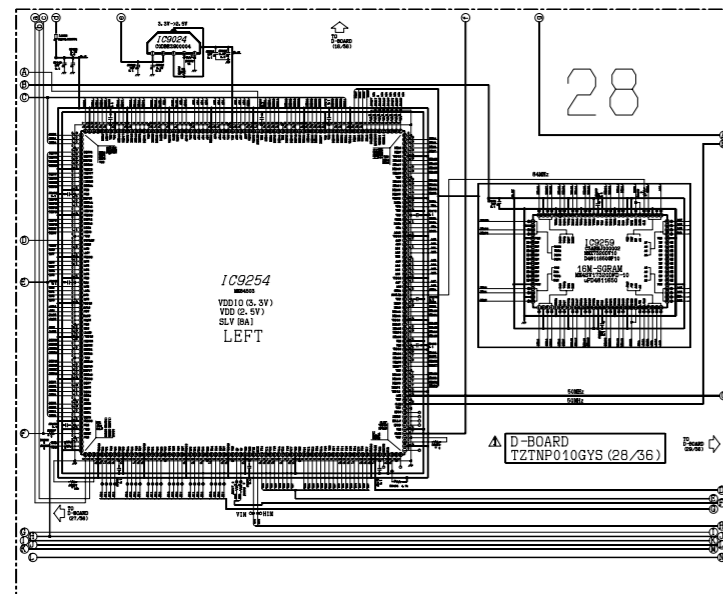
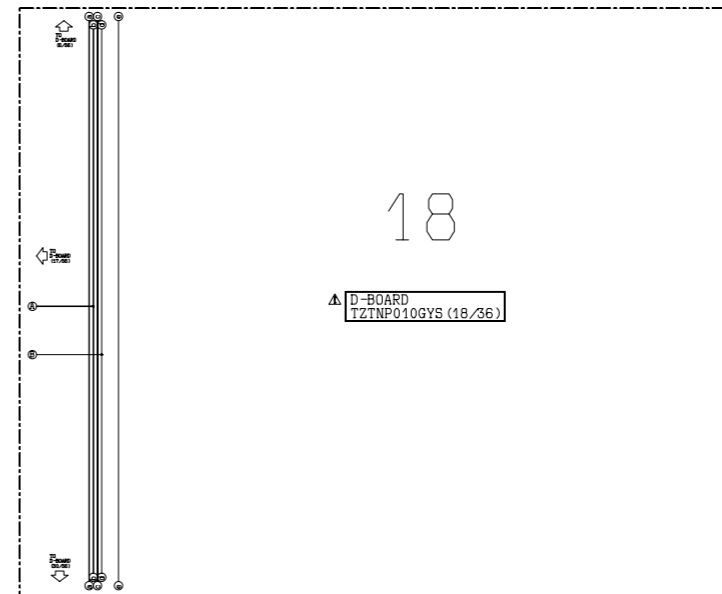
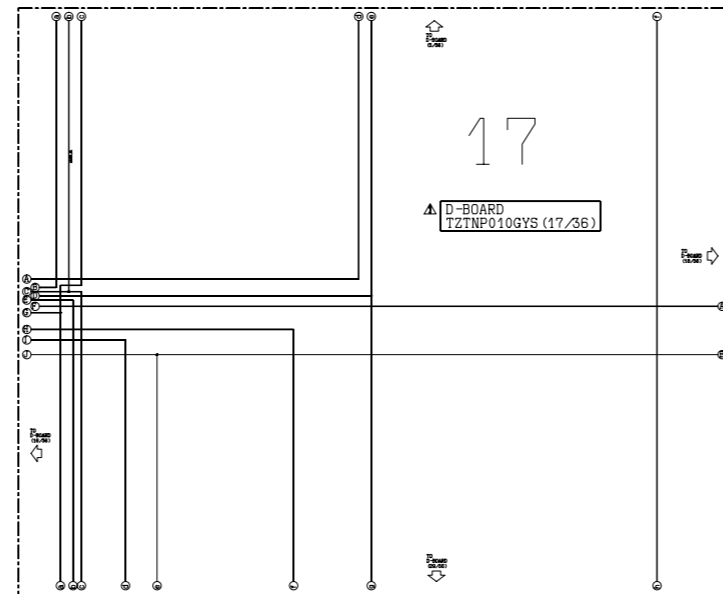
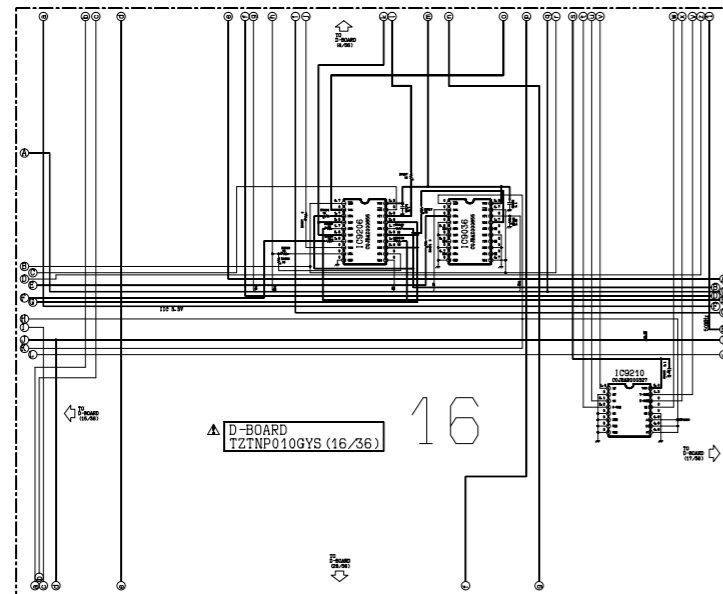
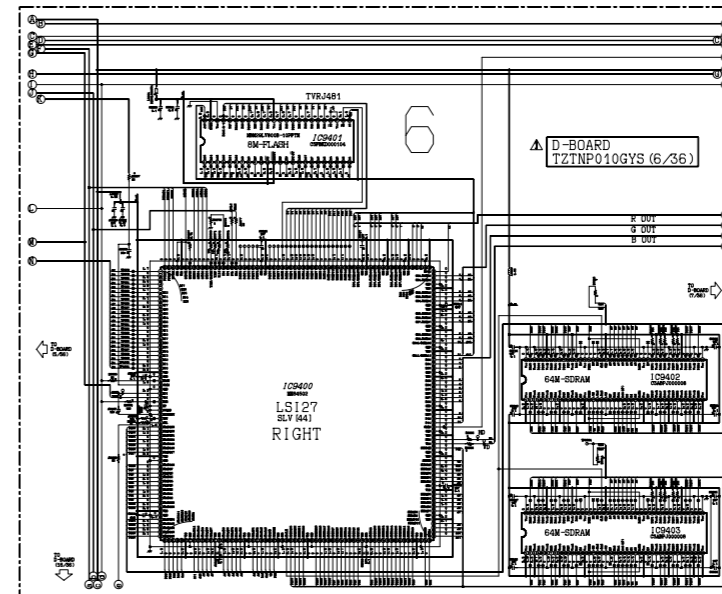
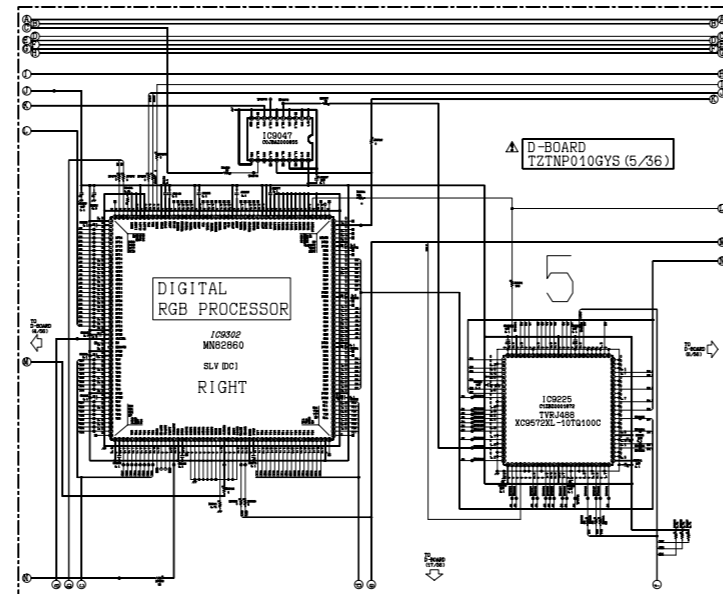
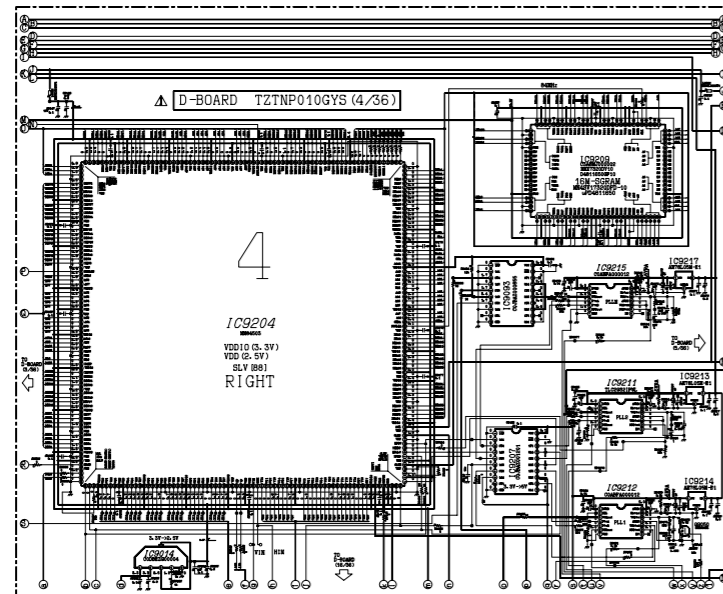



### 13.23. D-Board Information (3/4)

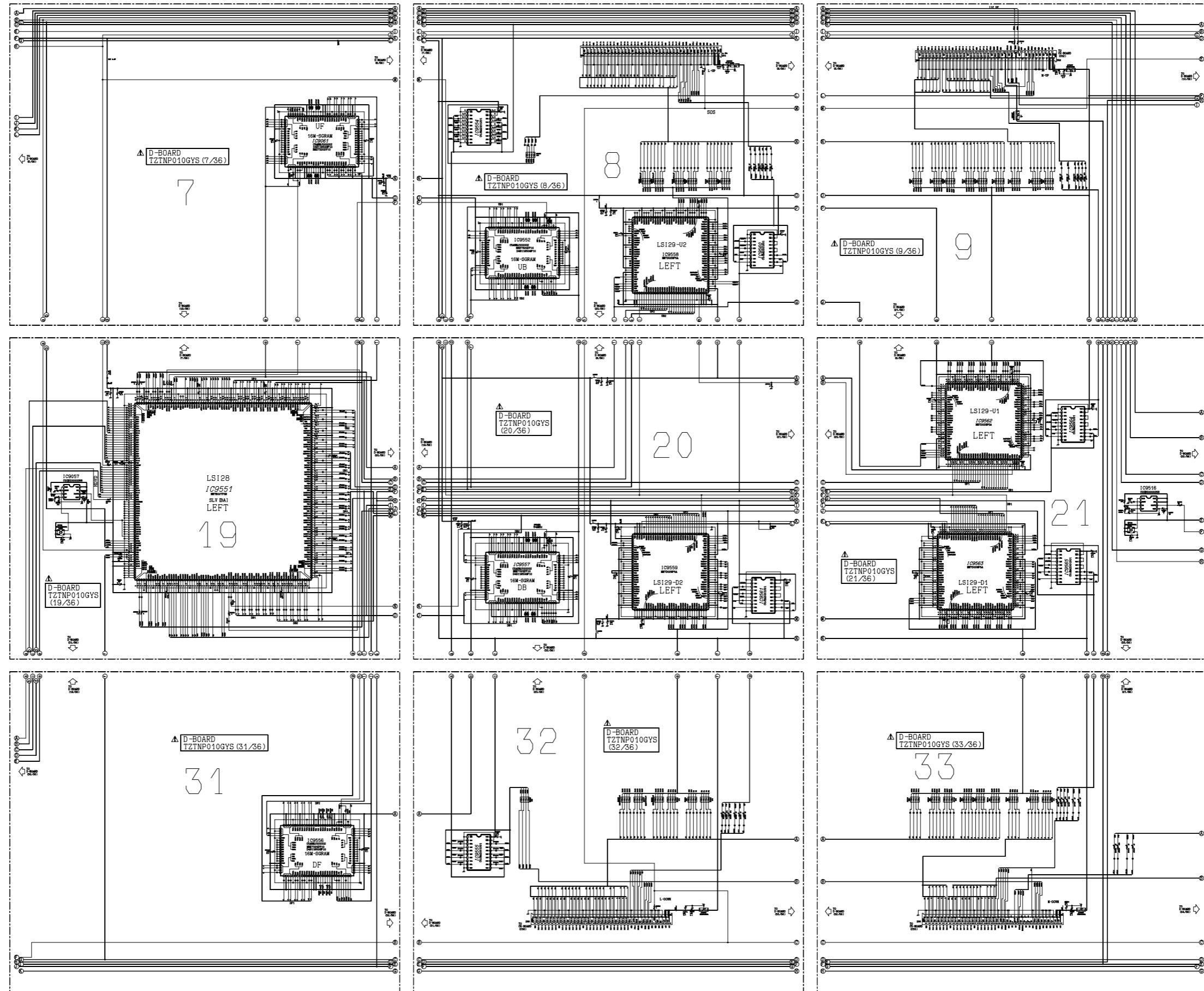

13.24. D-Board Information (4/4)

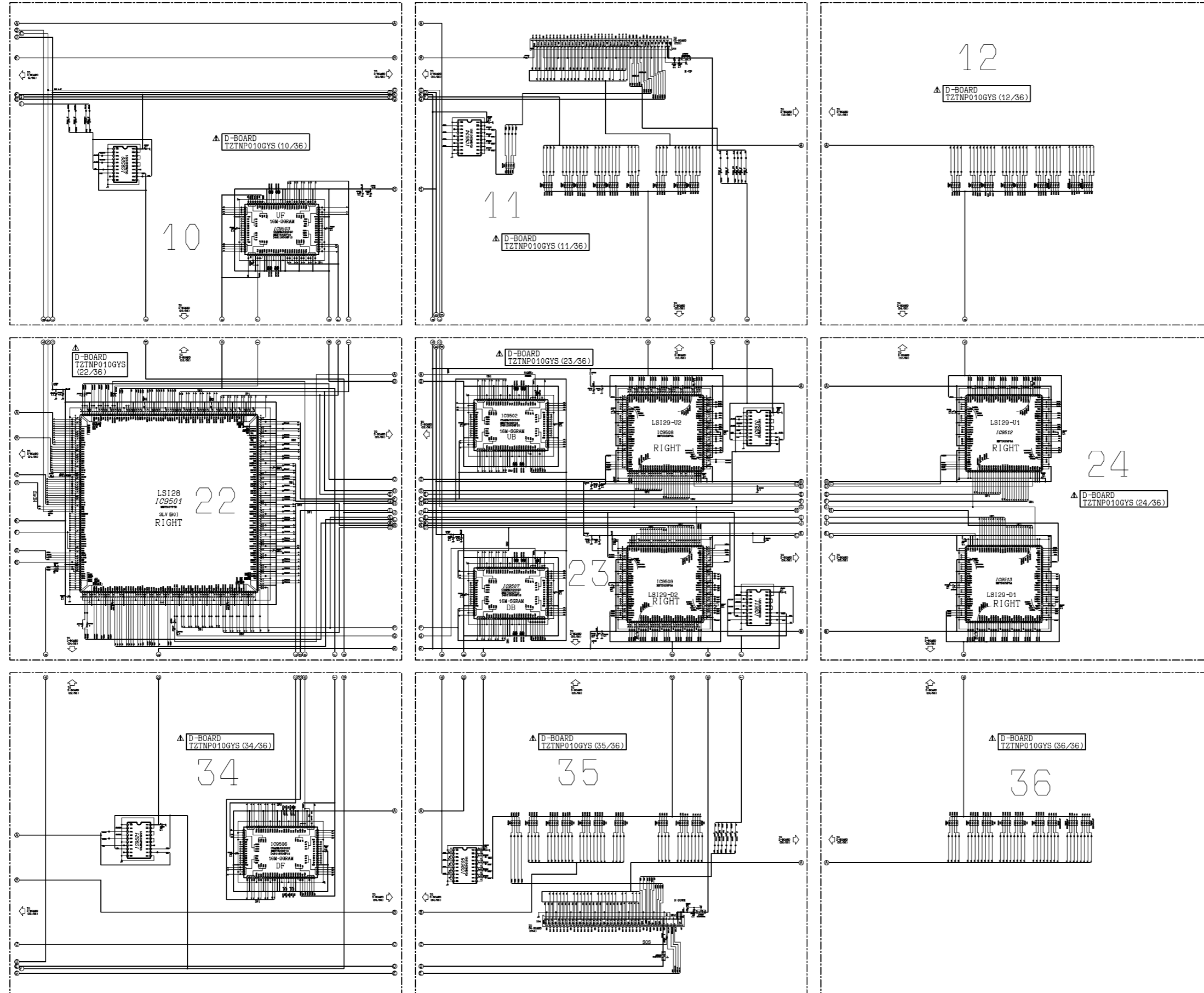

### 13.25. D-Board Block Diagram

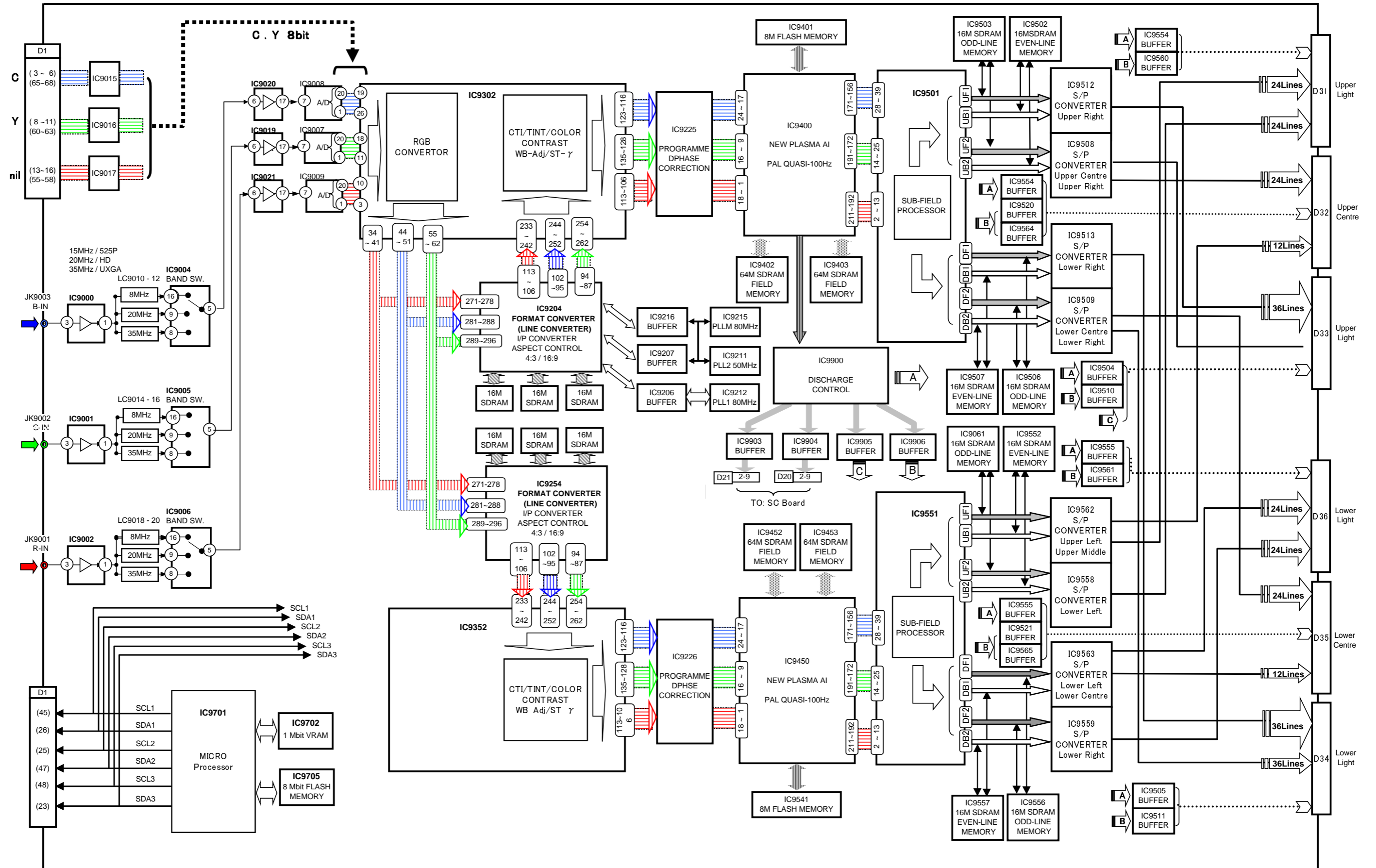

13.26. D-Board (1/36) Schematic Diagram

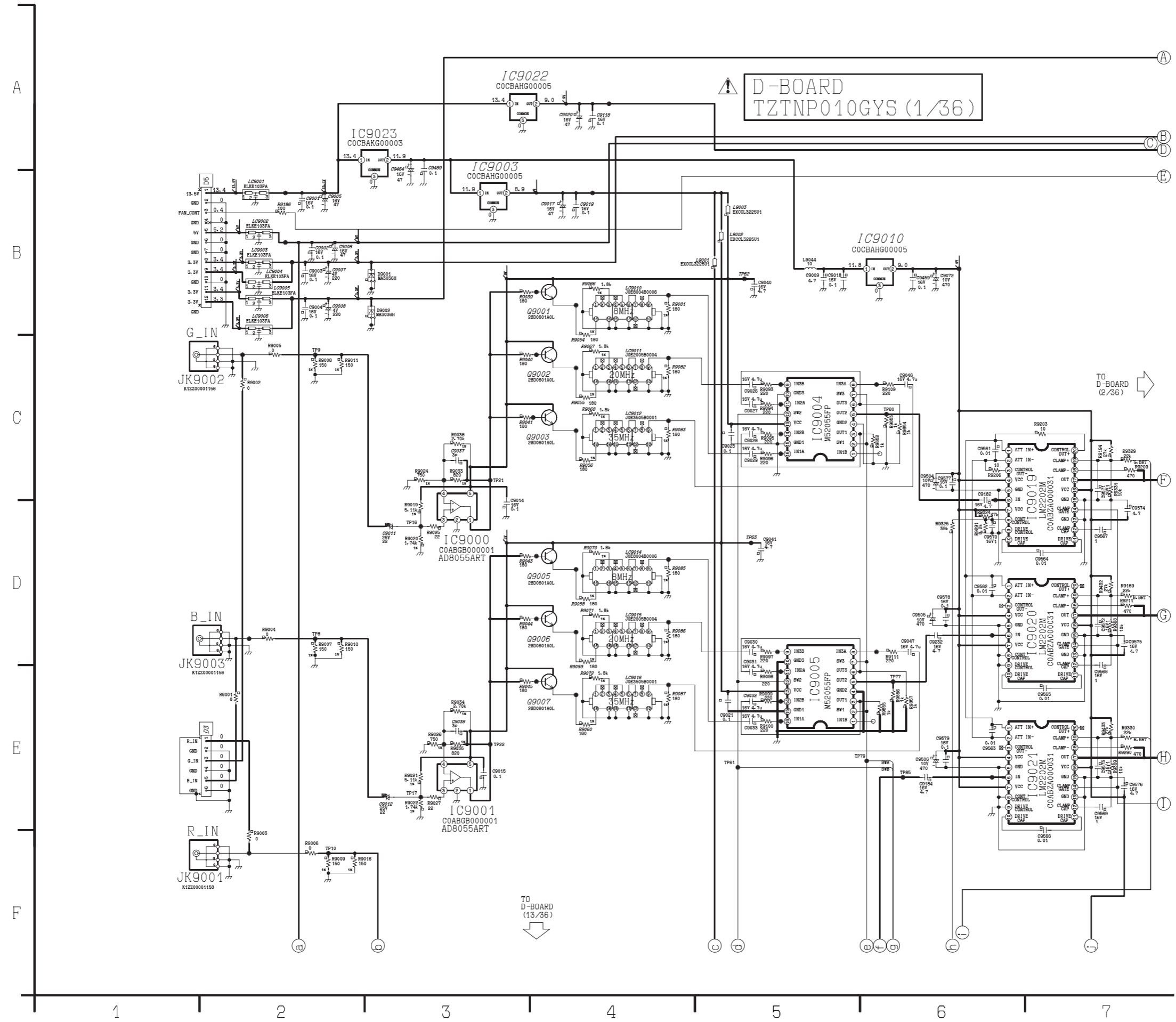

# 13.27. D-Board (2/36) Schematic Diagram

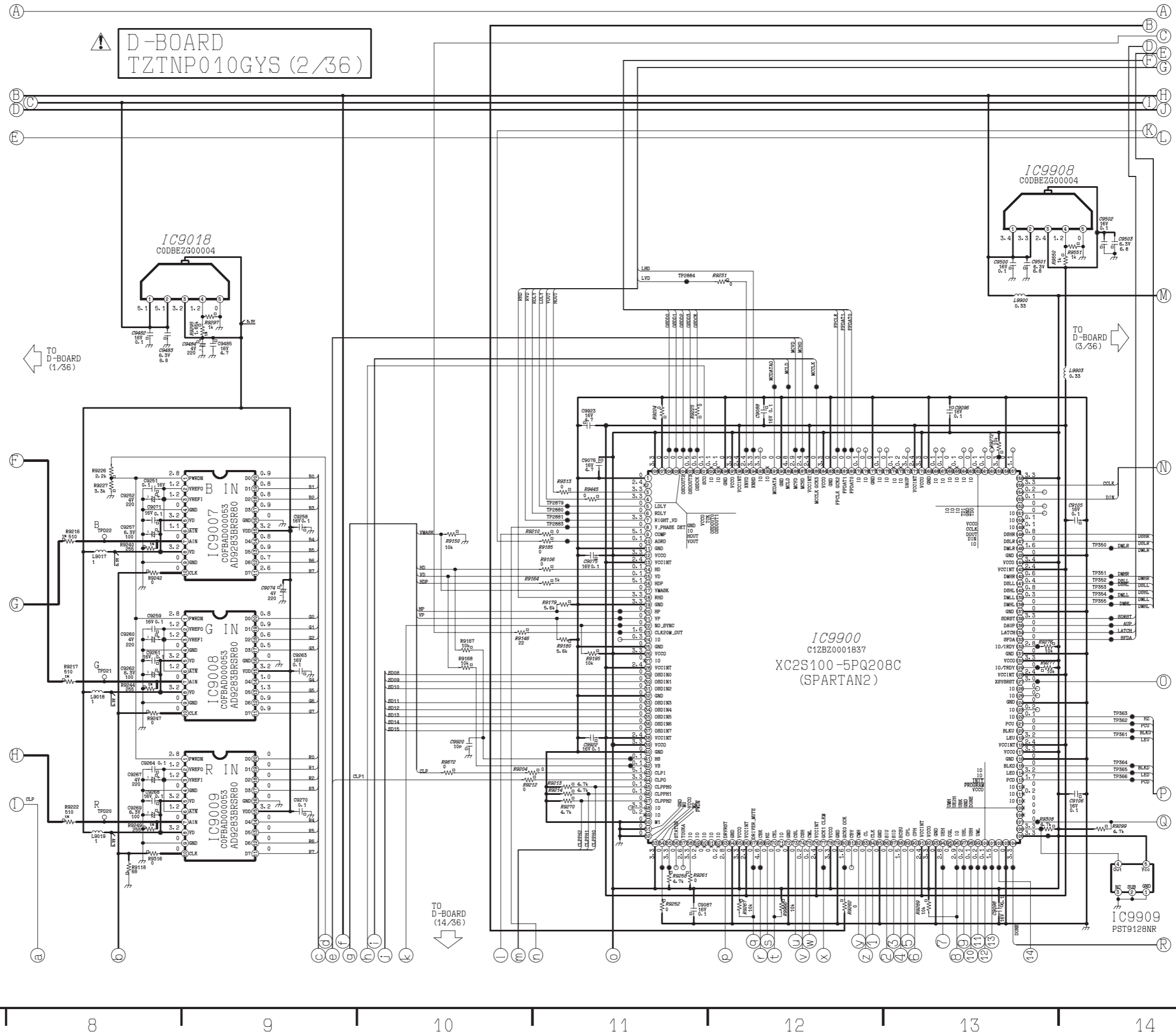

# 13.28. D-Board (3/36) Schematic Diagram

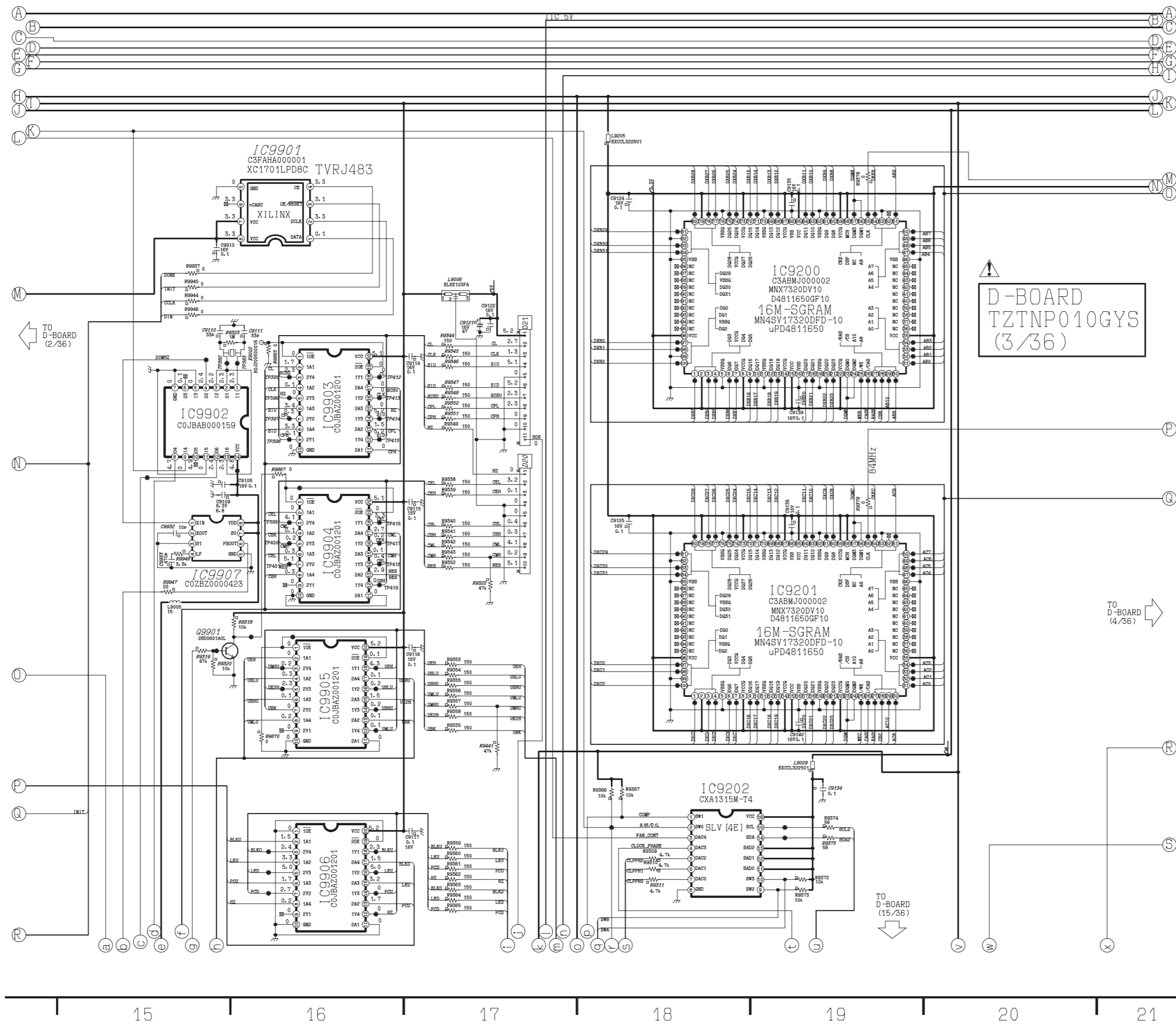

# 13.29. D-Board (4/36) Schematic Diagram

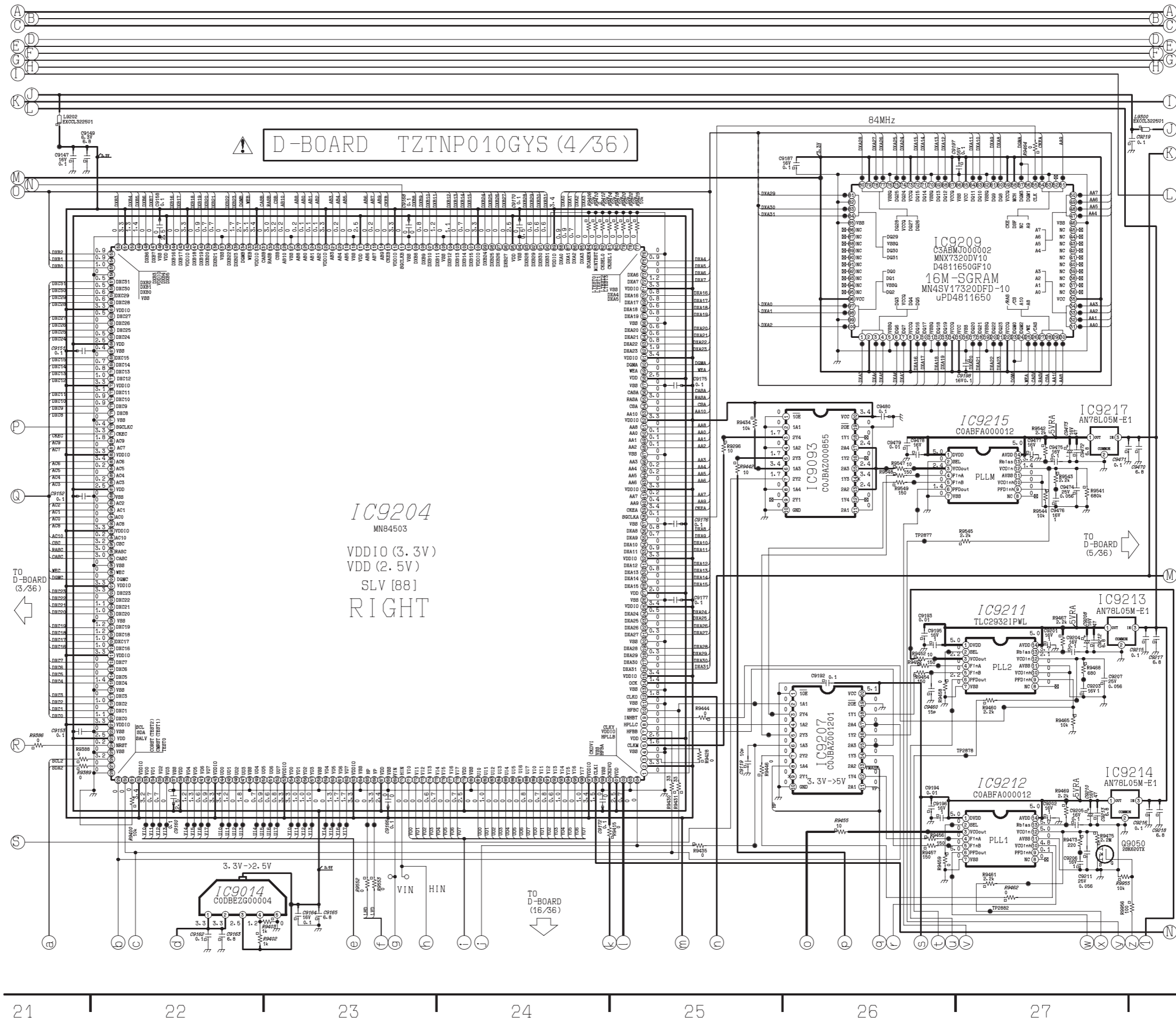

# 13.30. D-Board (5/36) Schematic Diagram

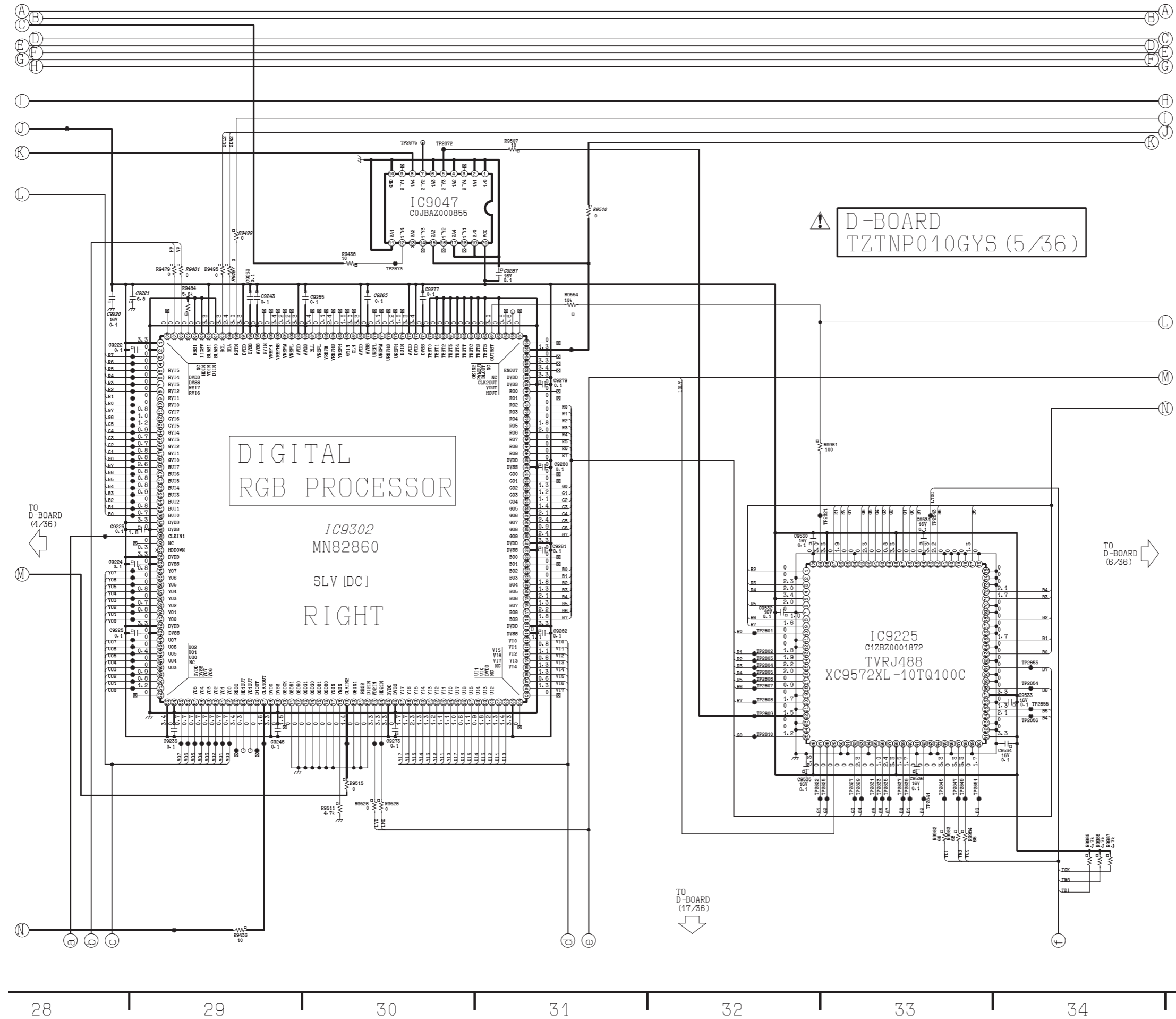



# 13.31. D-Board (6/36) Schematic Diagram

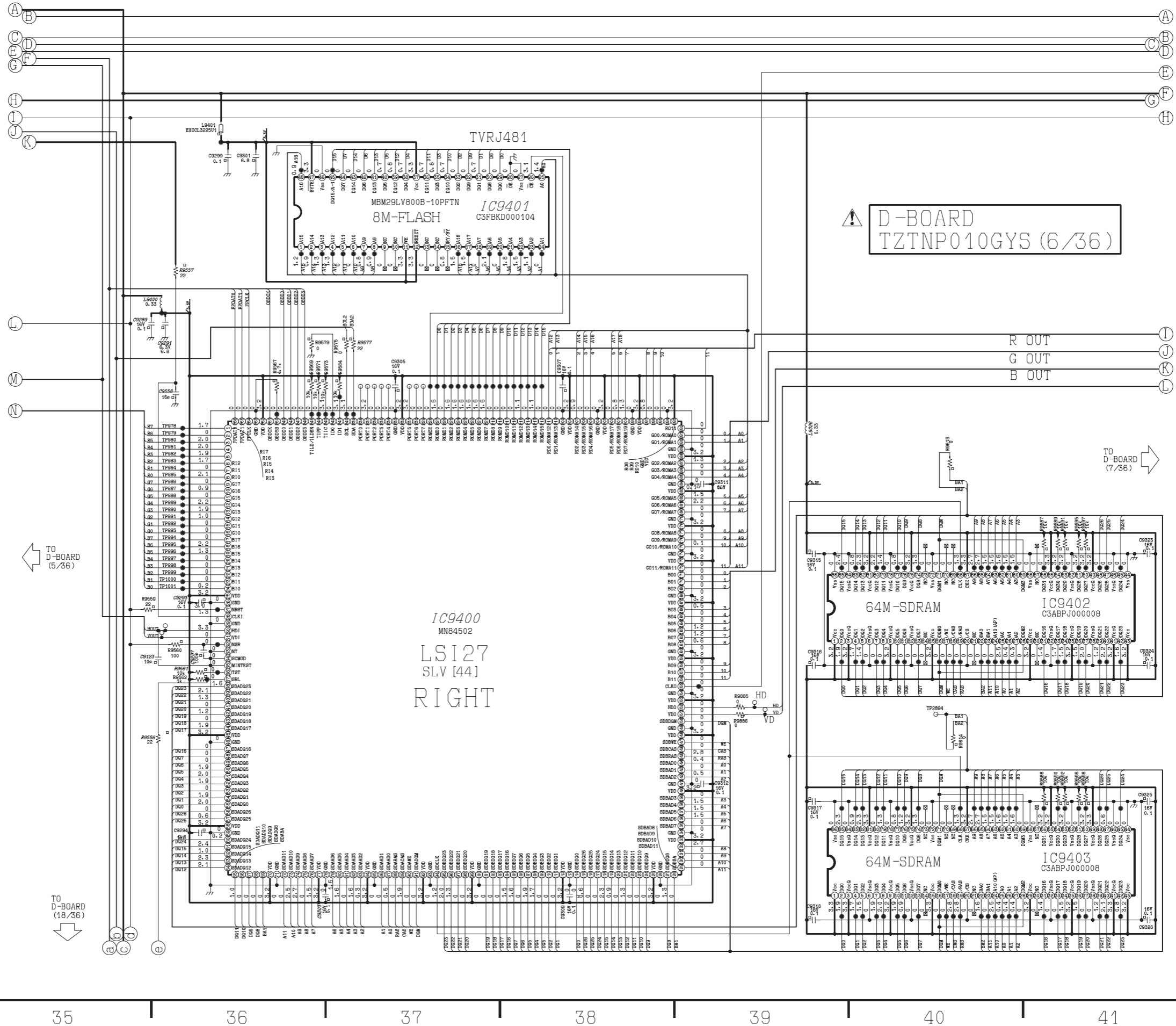

35

36

37

38

39

40

41

### 13.32. D-Board (7/36) Schematic Diagram

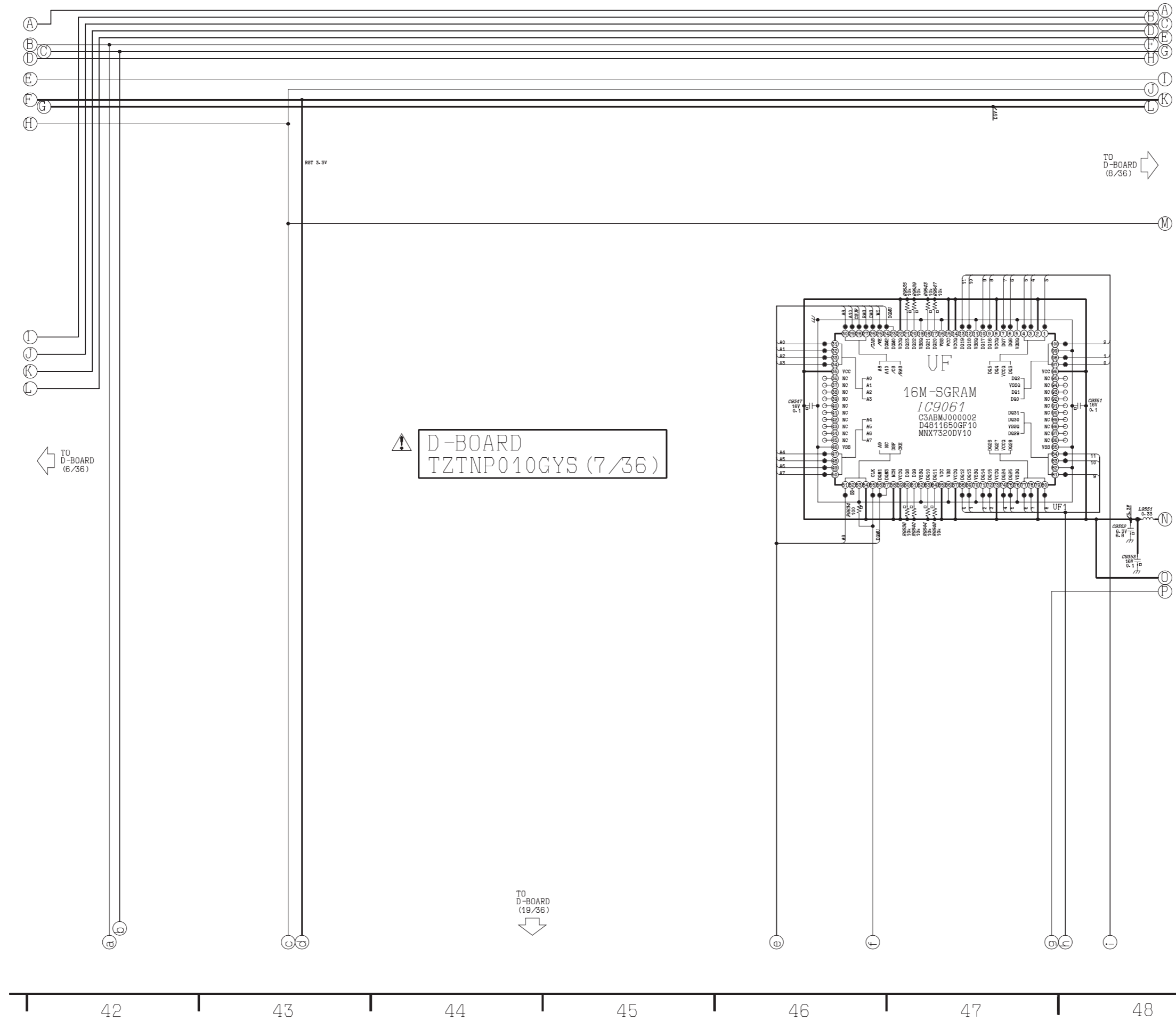

### 13.33. D-Board (8/36) Schematic Diagram

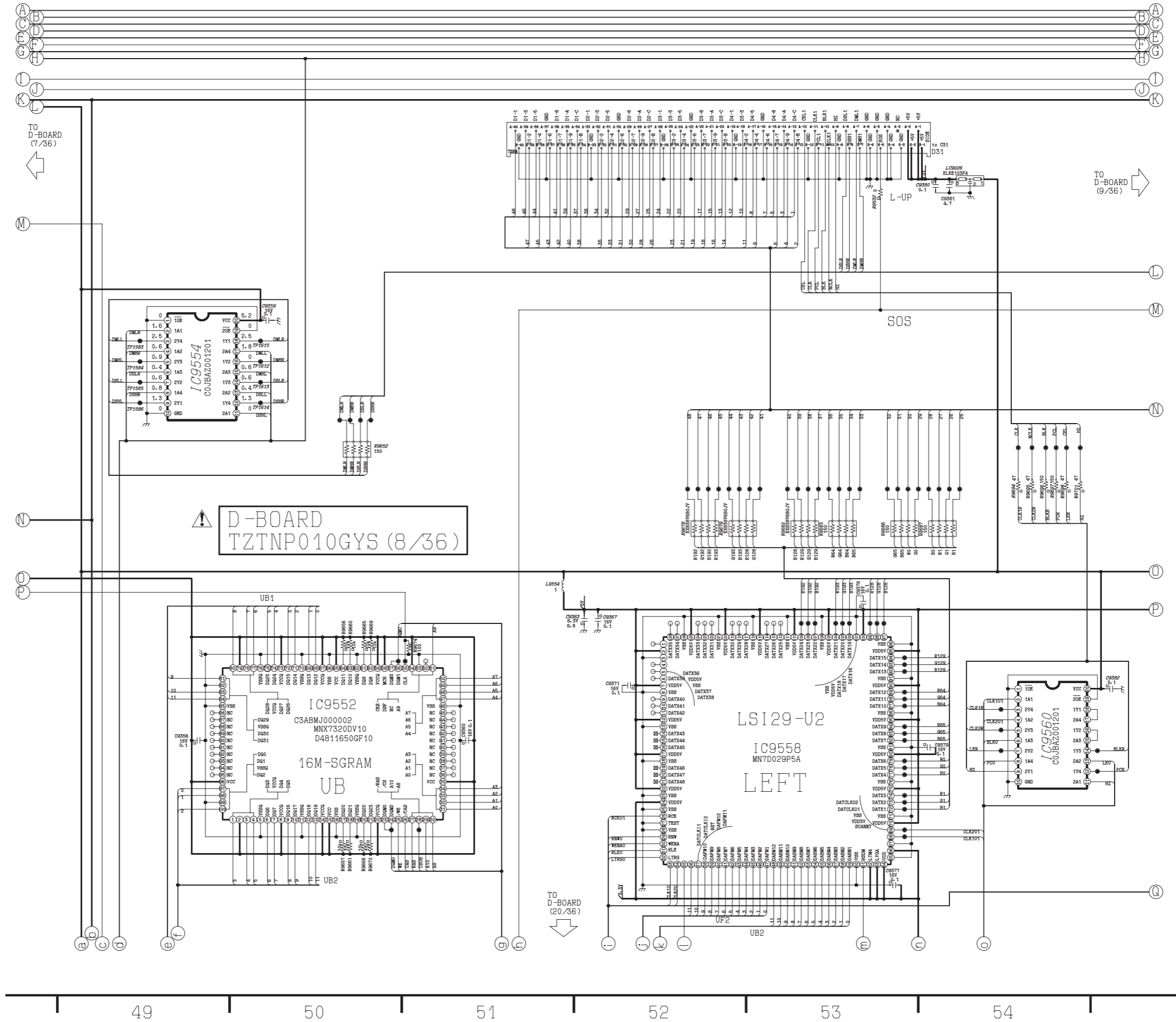

### 13.34. D-Board (9/36) Schematic Diagram

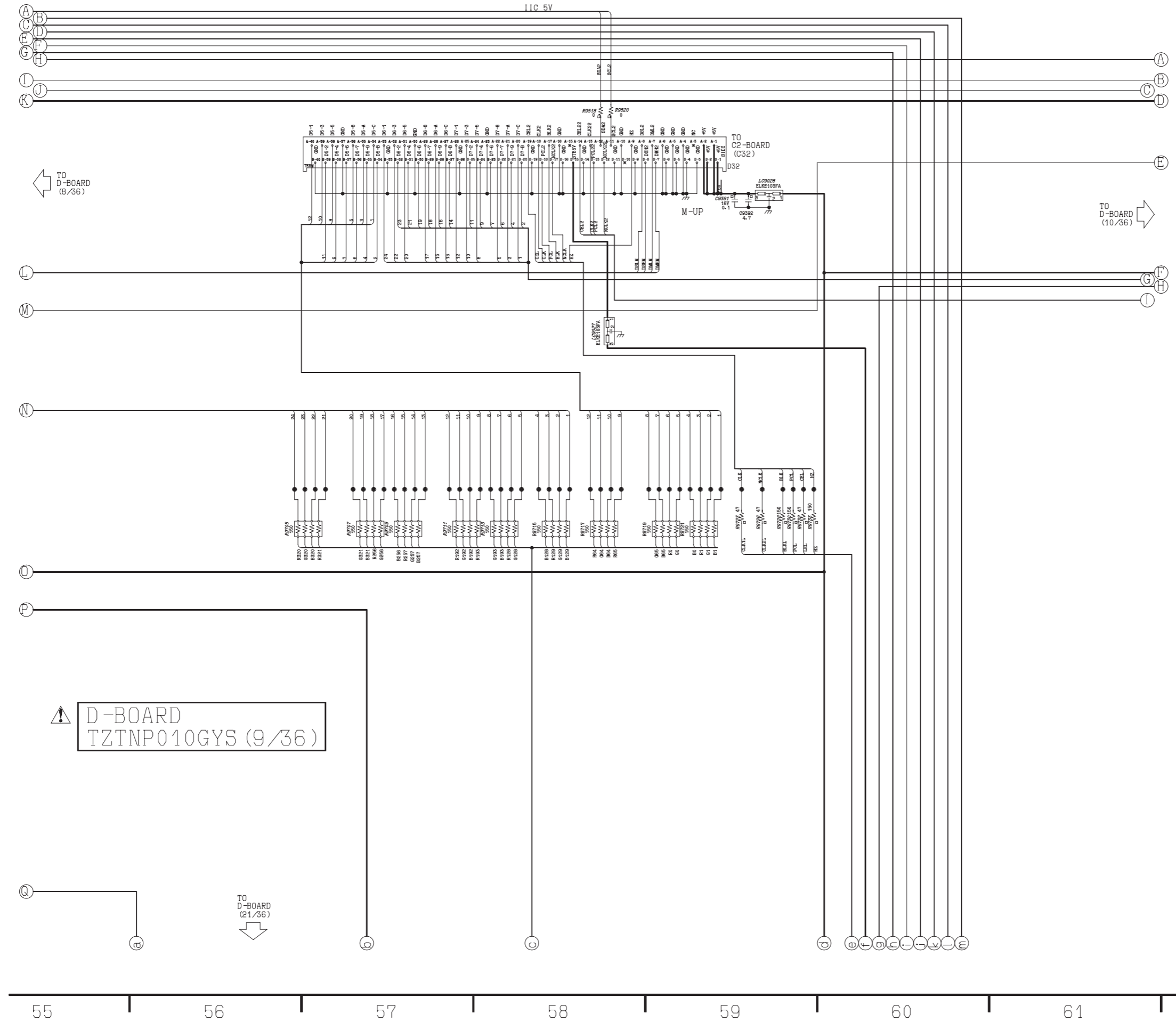

13.35. D-Board (10/36) Schematic Diagram

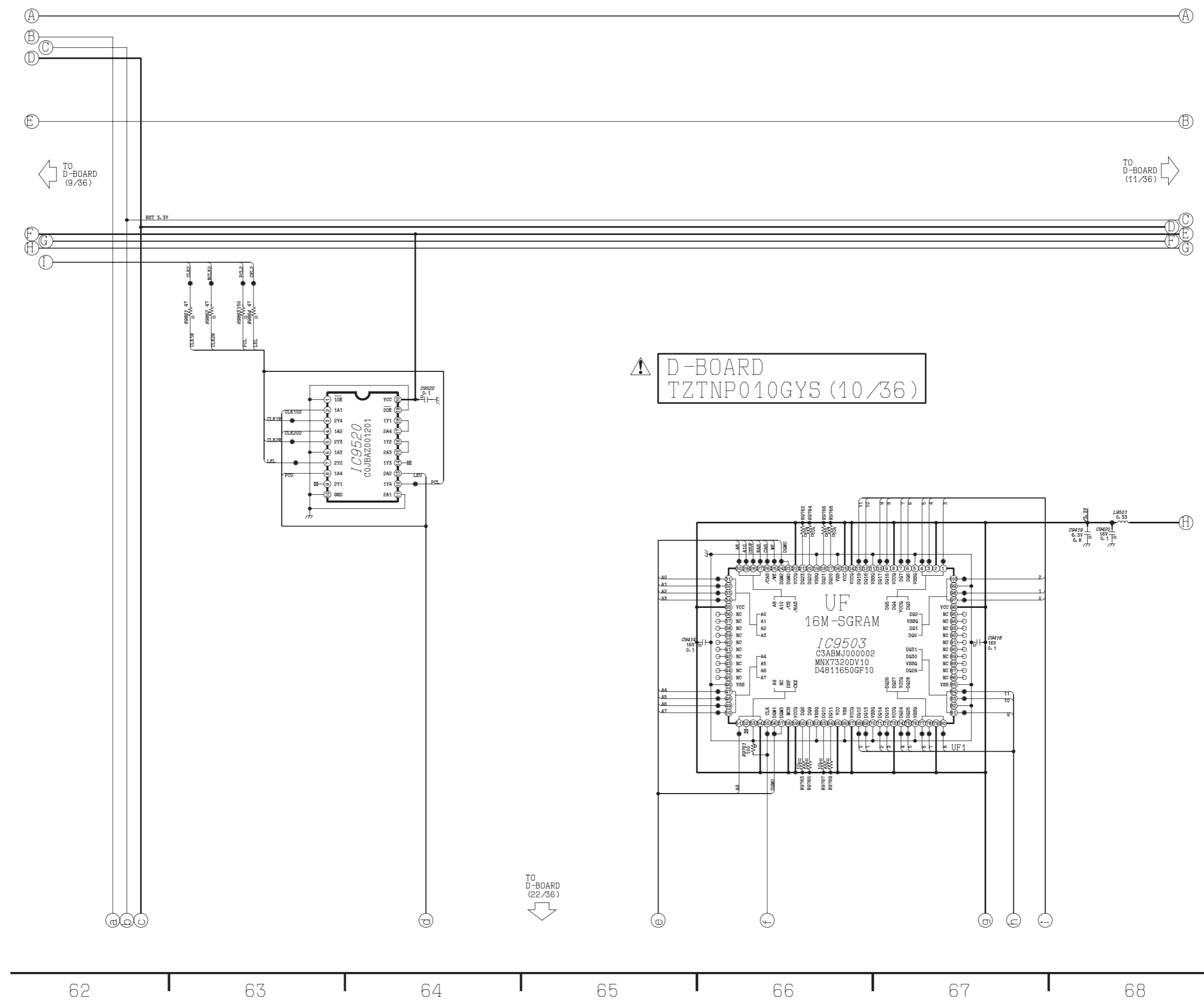

### 13.36. D-Board (11/36) Schematic Diagram

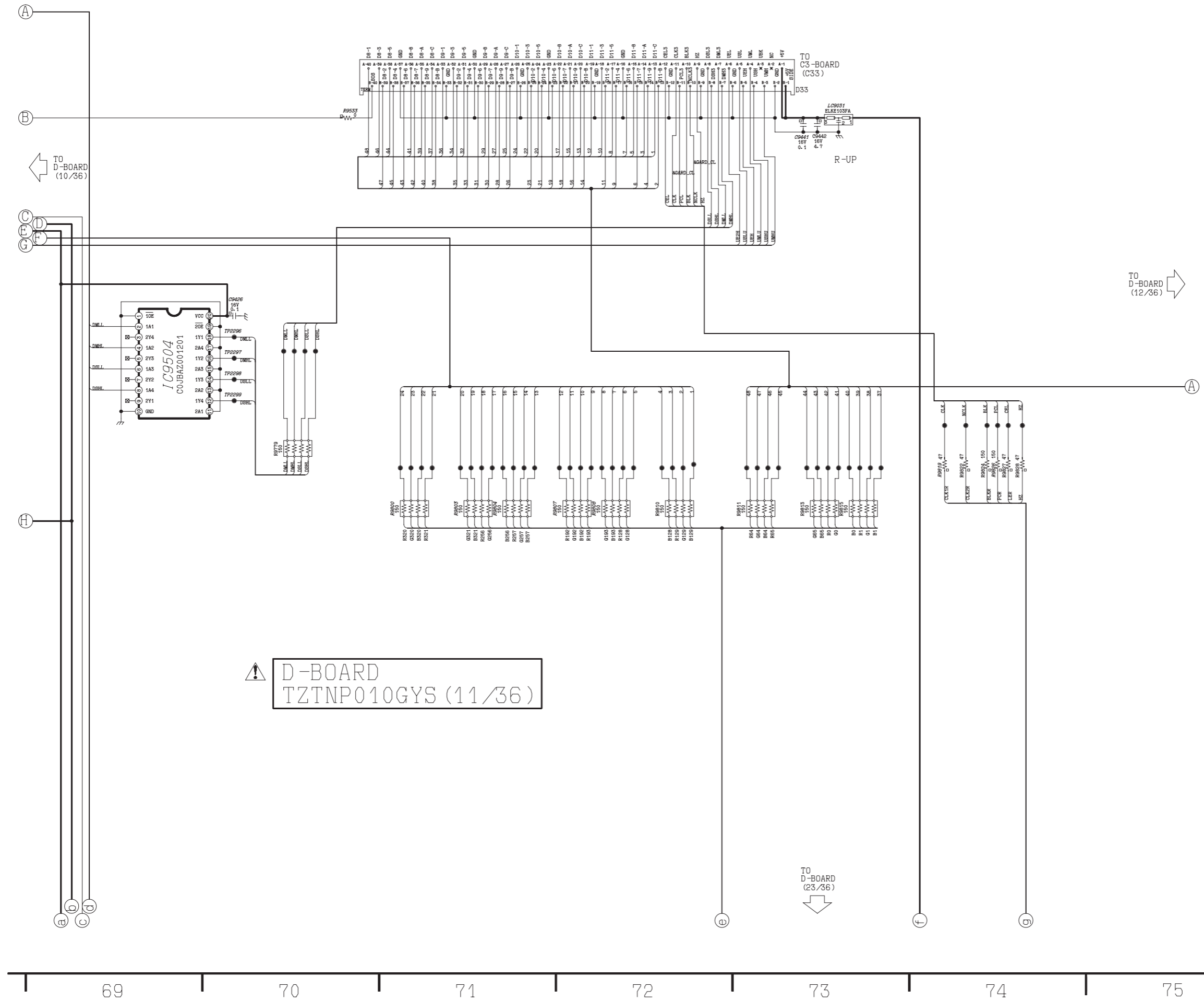

⚠ D-BOARD  
TZTNP010GYS (11/36)

13.37. D-Board (12/36) Schematic Diagram

 **D-BOARD**  
TZNPO10GYS (12/36)

← TO  
D-BOARD  
(11/36)

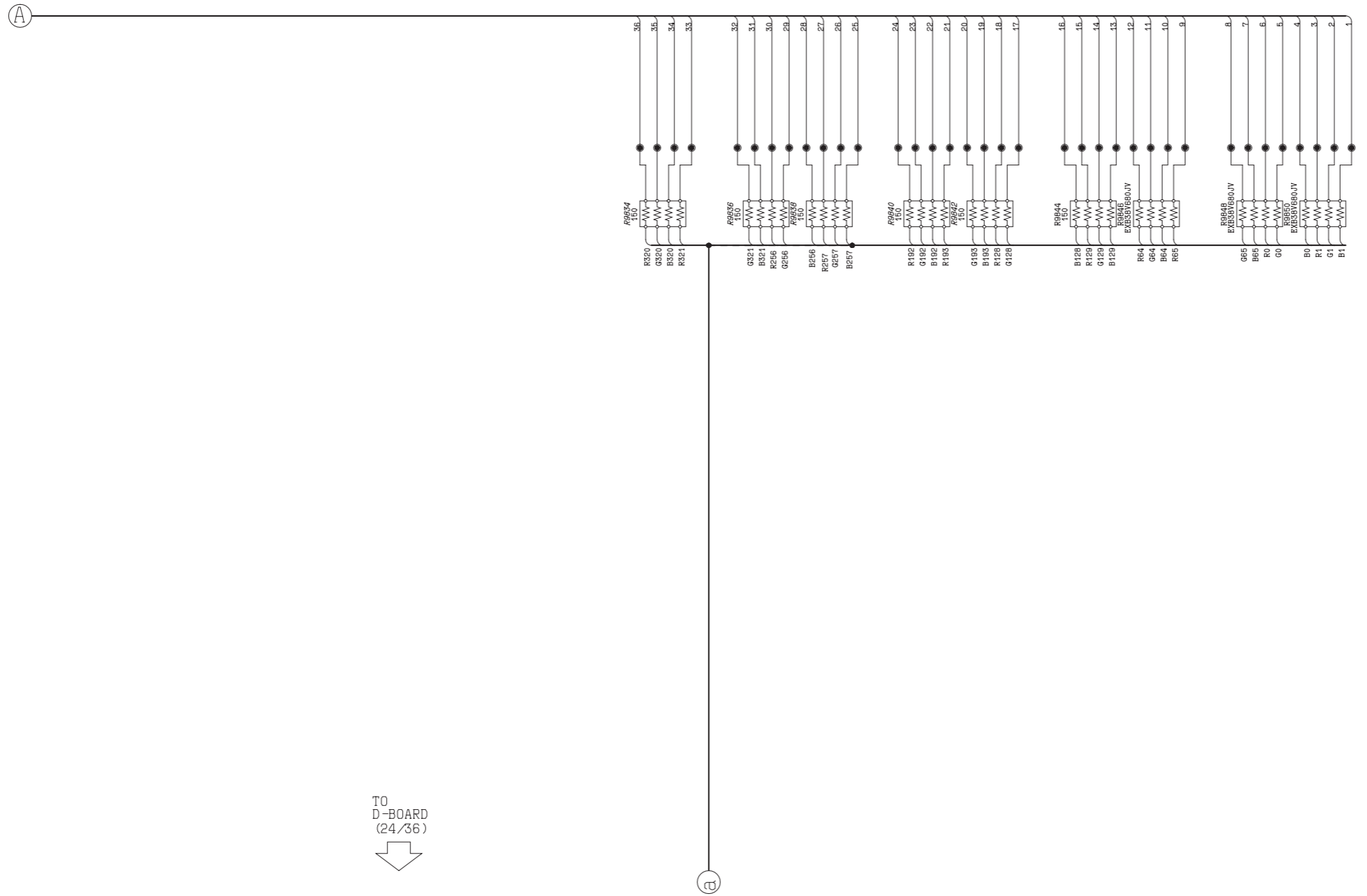

TO  
D-BOARD  
(24/36)  
↓



# 13.38. D-Board (13/36) Schematic Diagram

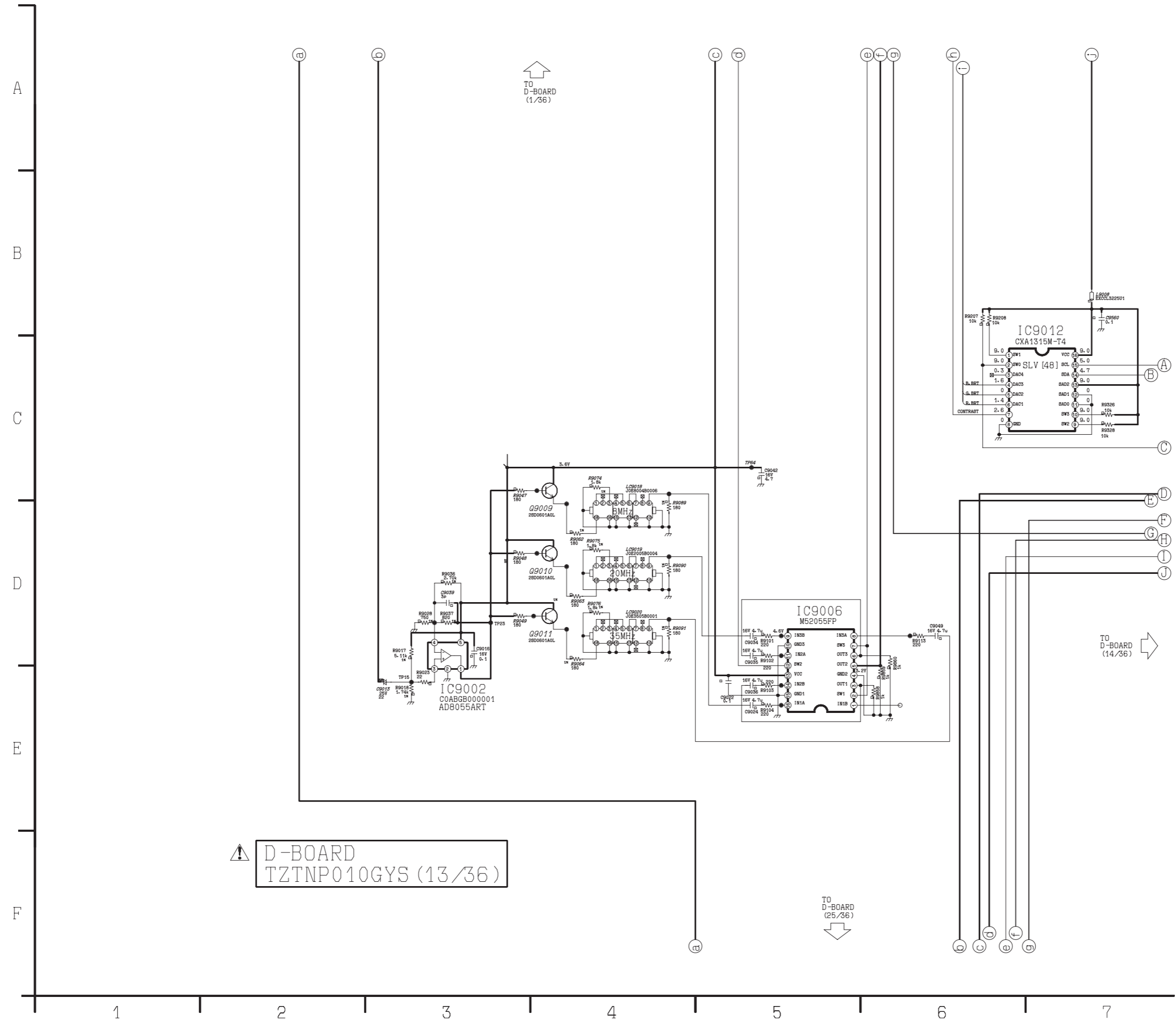



# 13.39. D-Board (14/36) Schematic Diagram

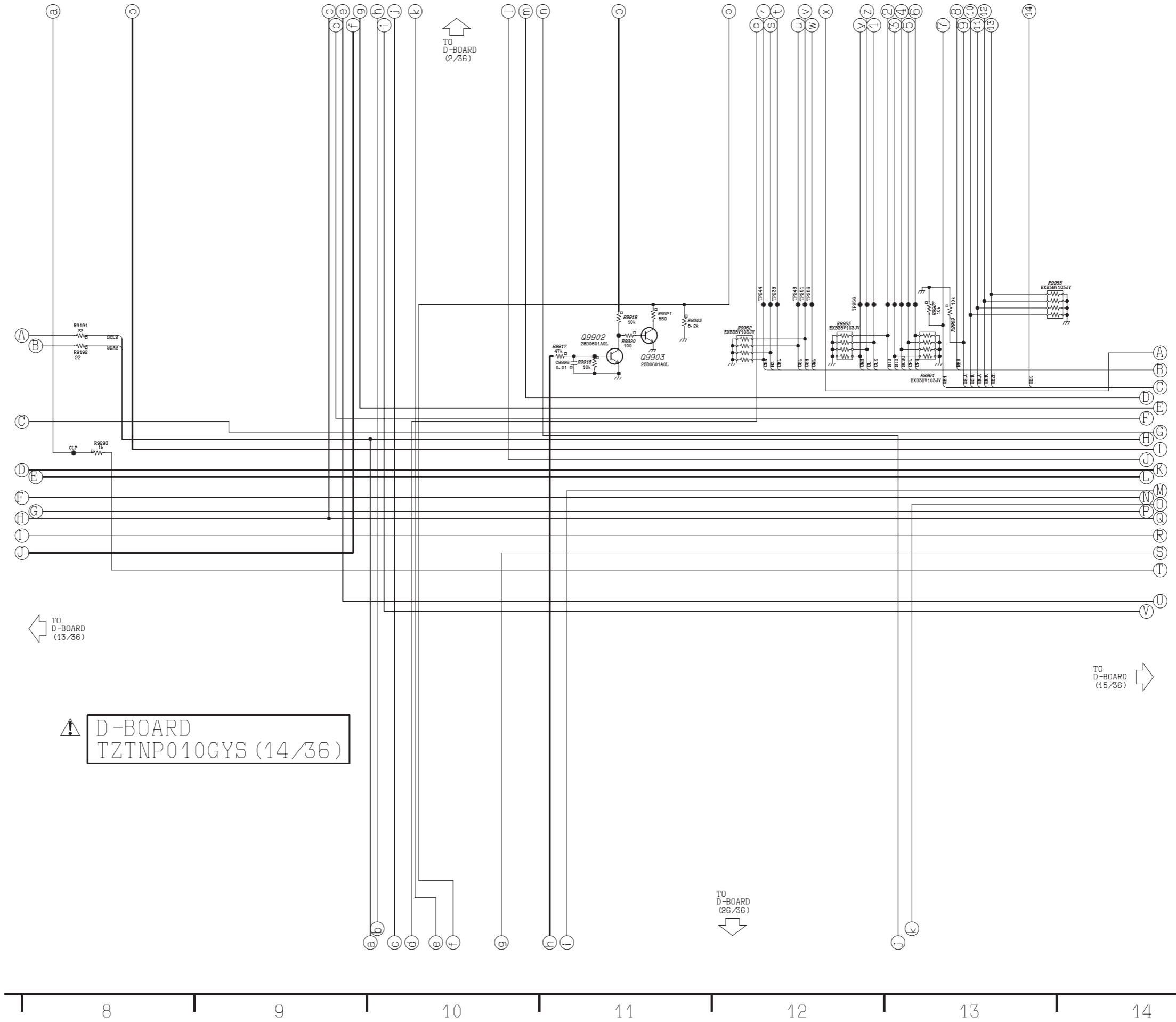

⚠ D-BOARD  
TZTNP010GYS (14/36)

### 13.40. D-Board (15/36) Schematic Diagram

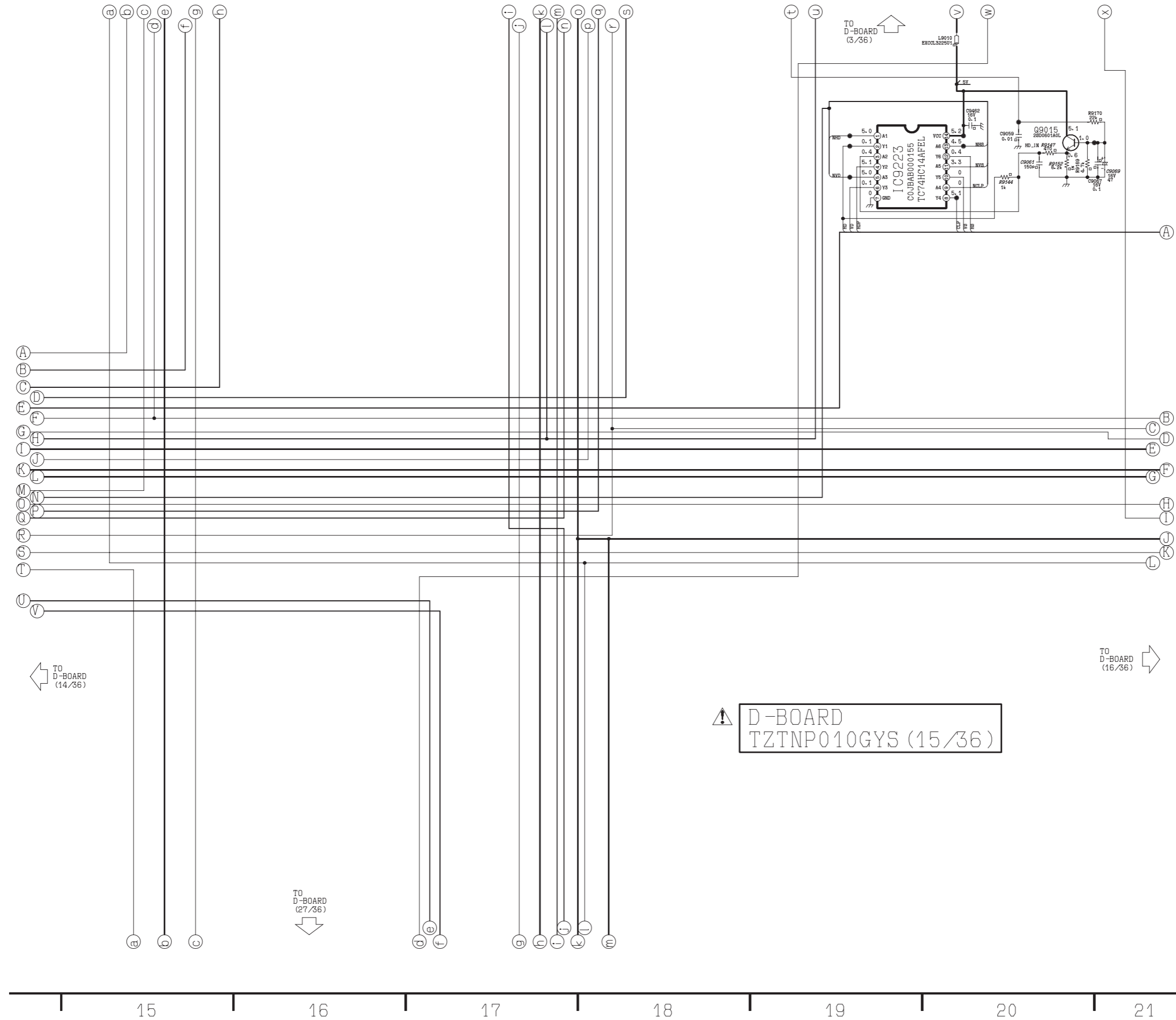

# 13.41. D-Board (16/36) Schematic Diagram

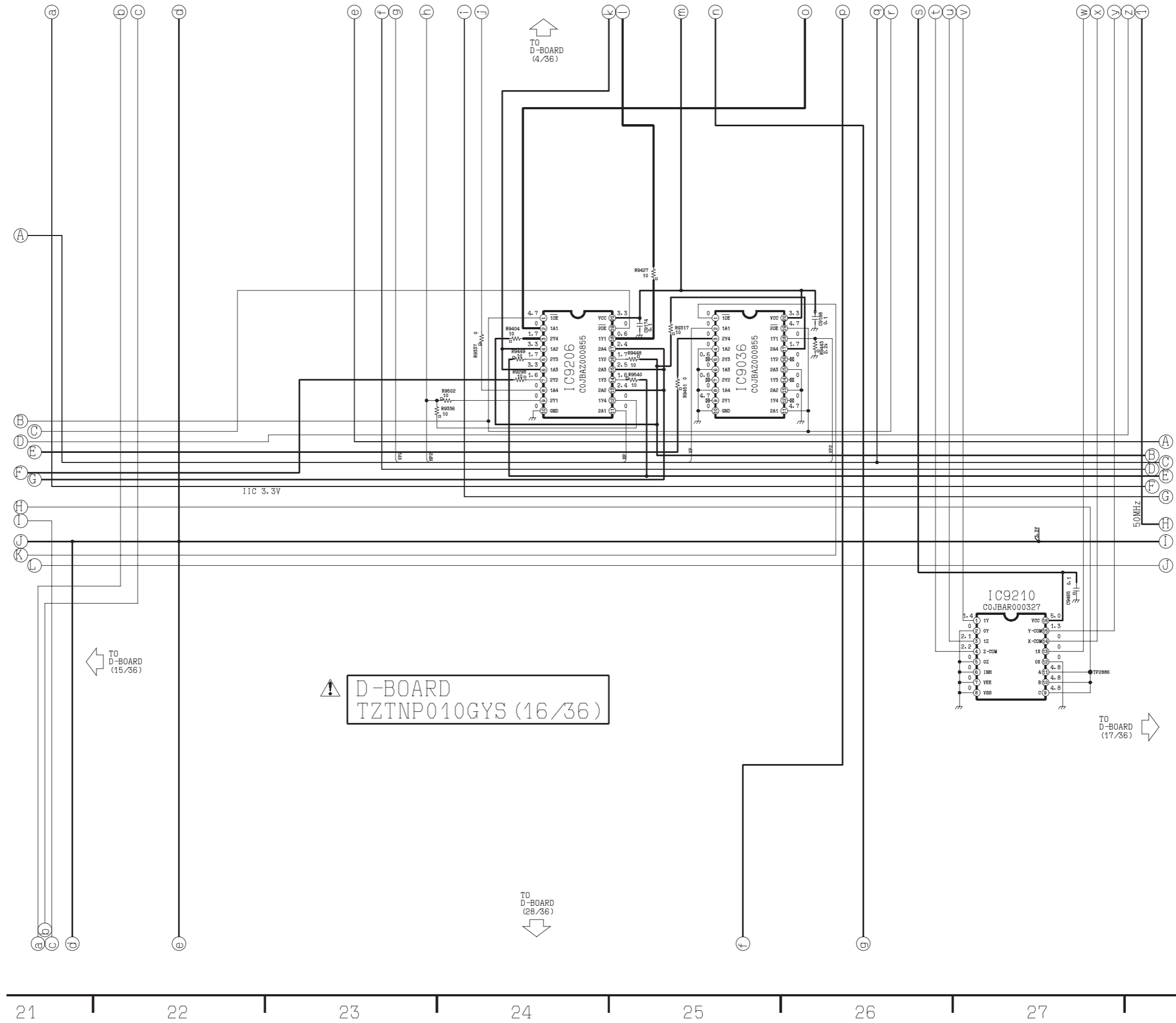

### 13.42. D-Board (17/36) Schematic Diagram

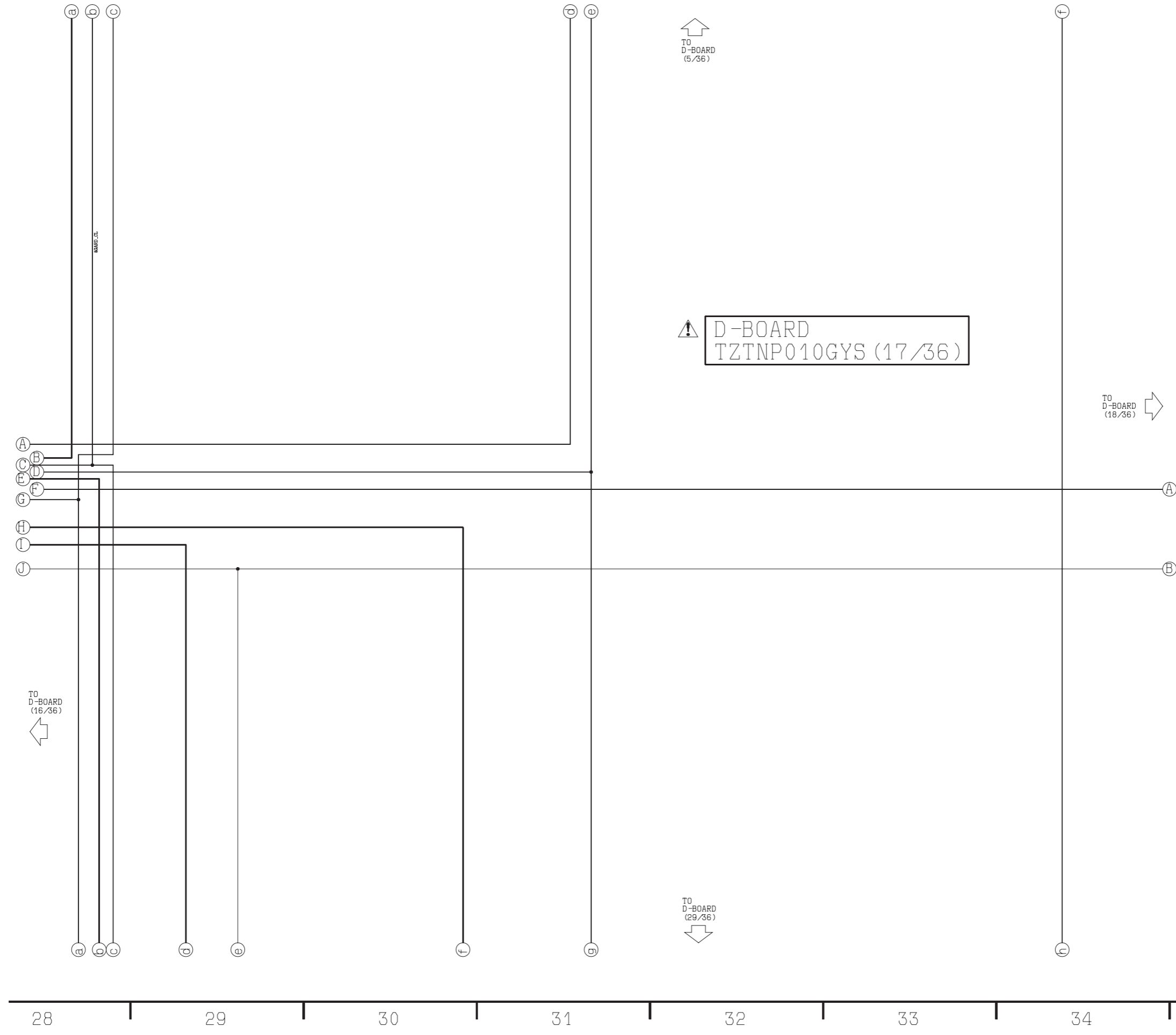

### 13.43. D-Board (18/36) Schematic Diagram

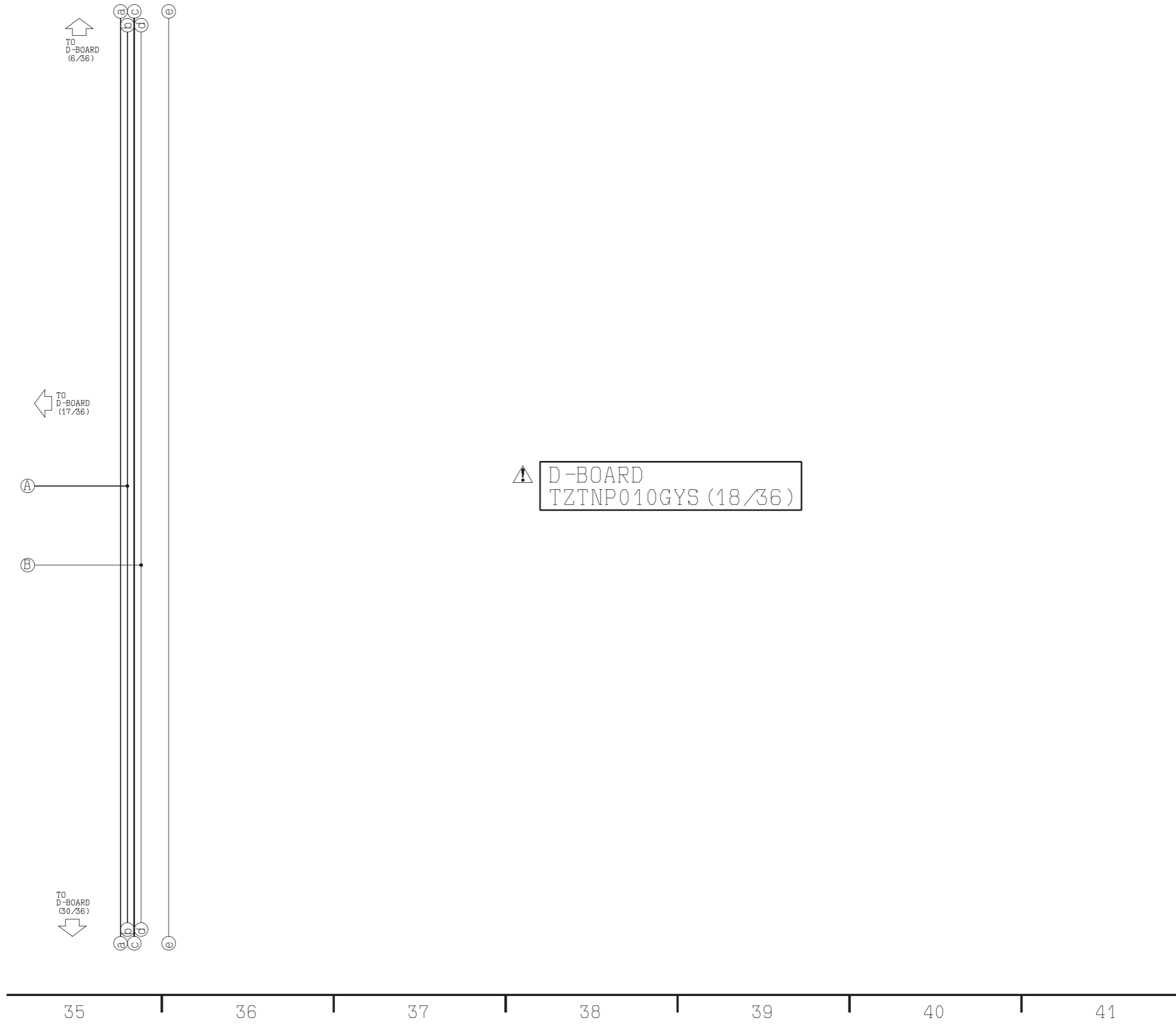

# 13.44. D-Board (19/36) Schematic Diagram

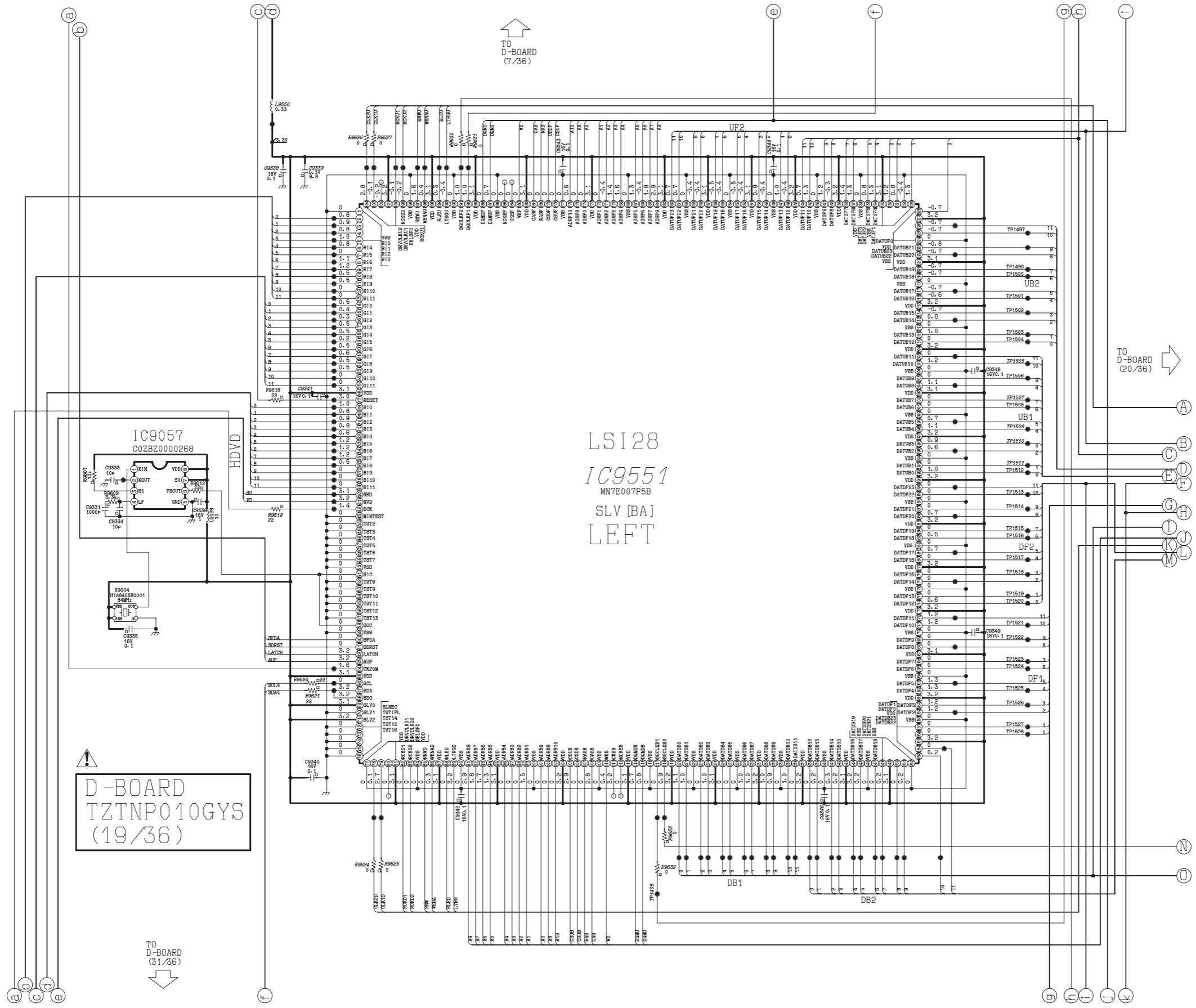

42

43

44

45

46

47

48

# 13.45. D-Board (20/36) Schematic Diagram

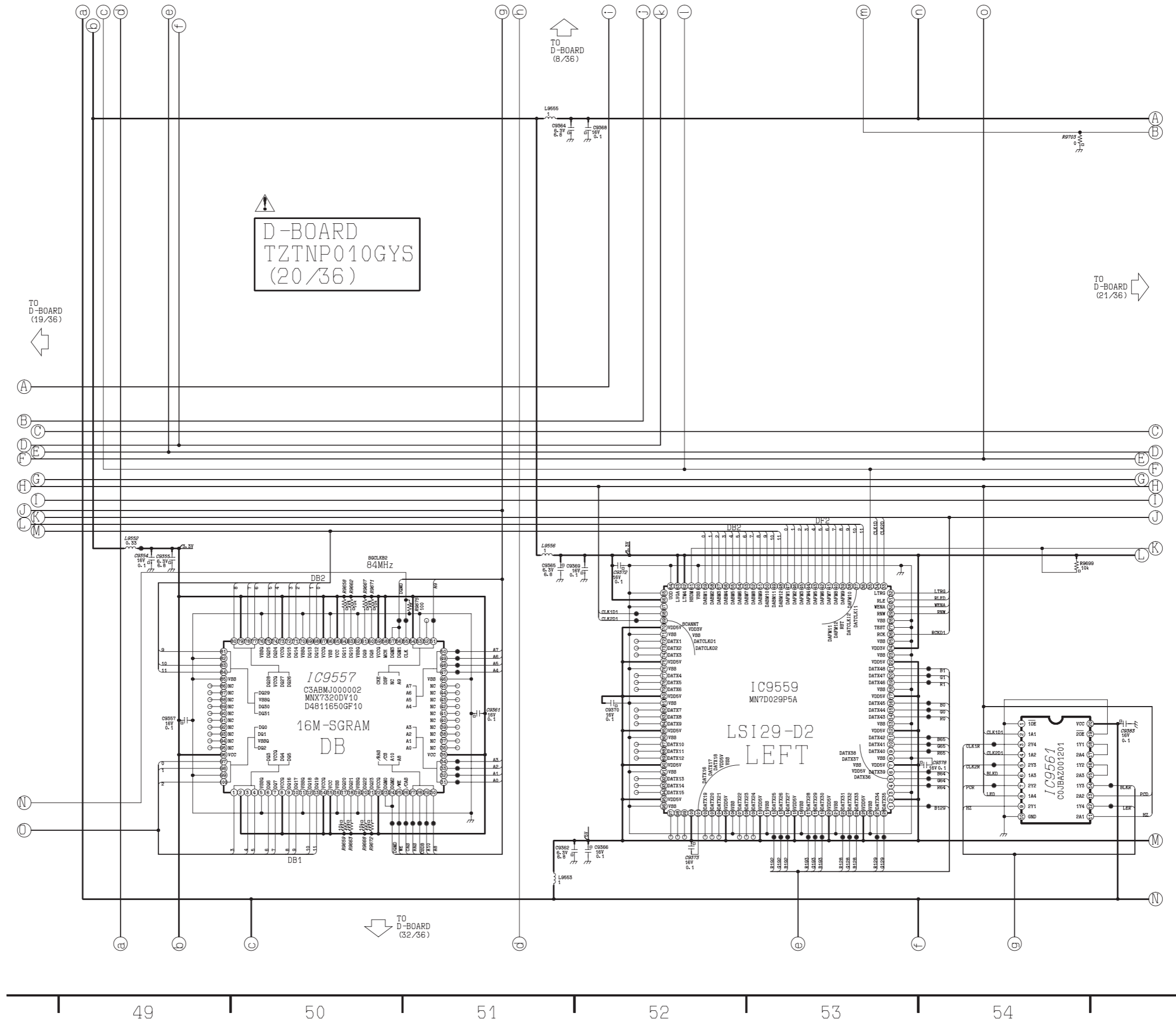

# 13.46. D-Board (21/36) Schematic Diagram

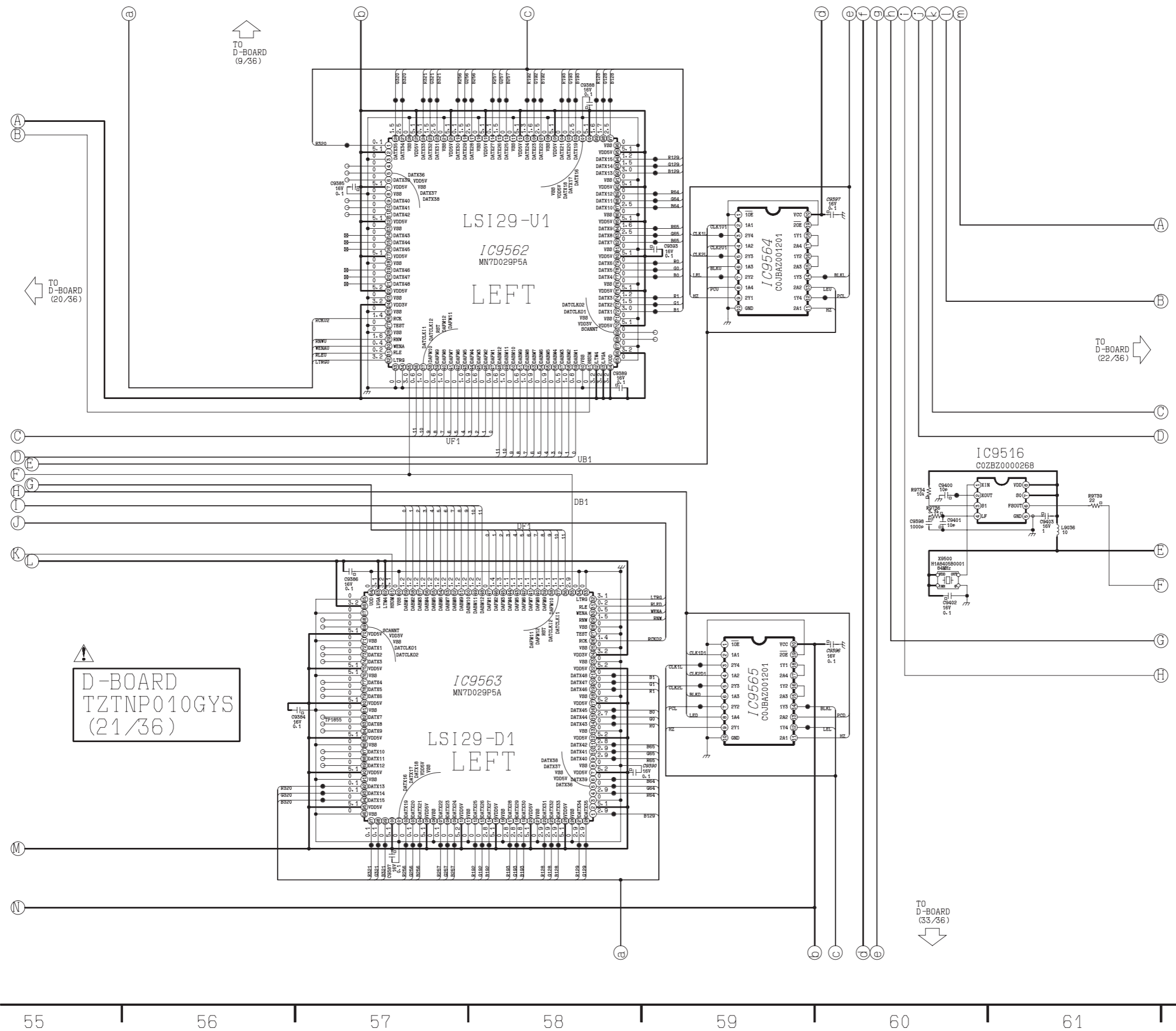



# 13.47. D-Board (22/36) Schematic Diagram

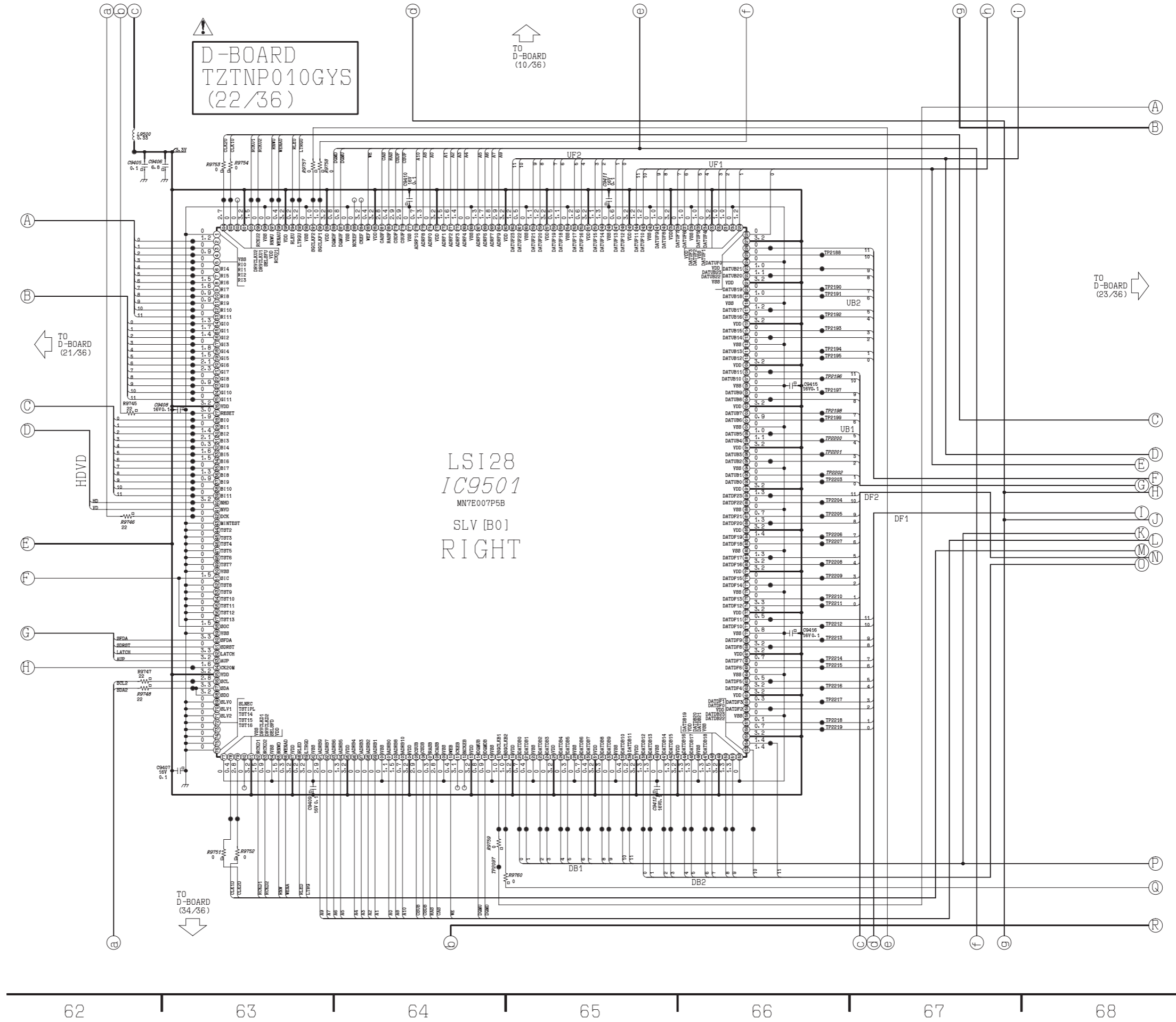

# 13.48. D-Board (23/36) Schematic Diagram

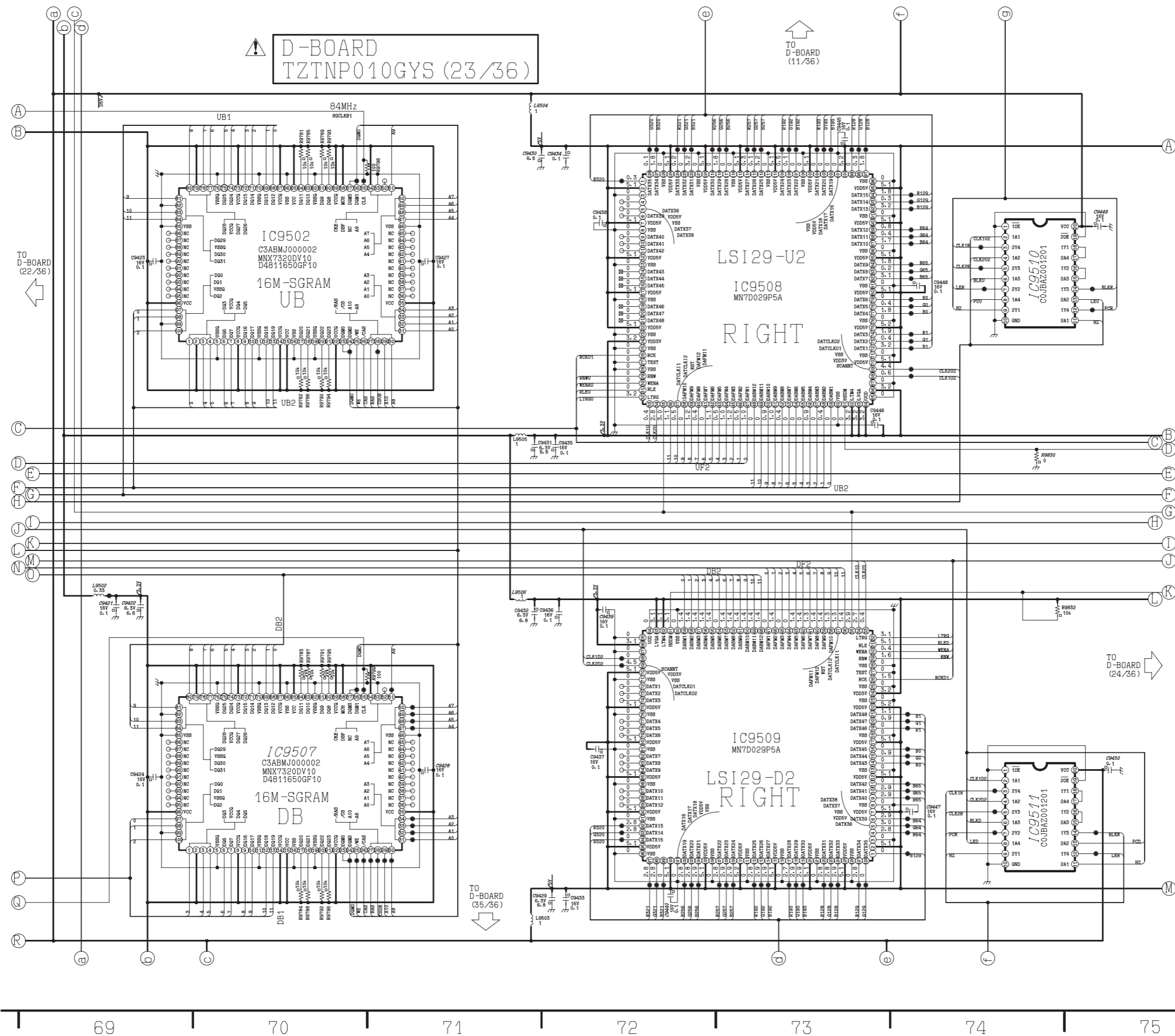

# 13.49. D-Board (24/36) Schematic Diagram

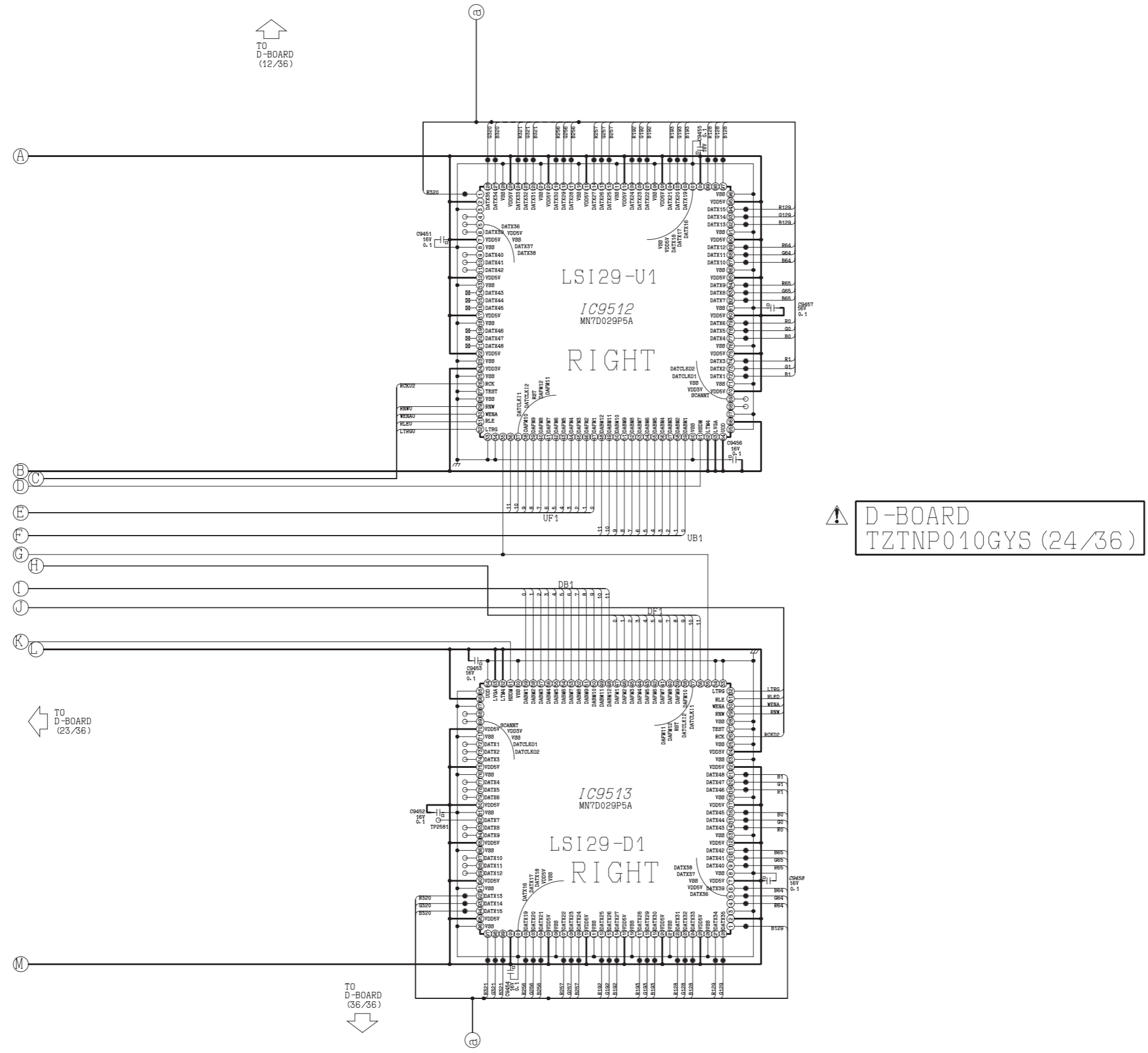





### 13.52. D-Board (27/36) Schematic Diagram

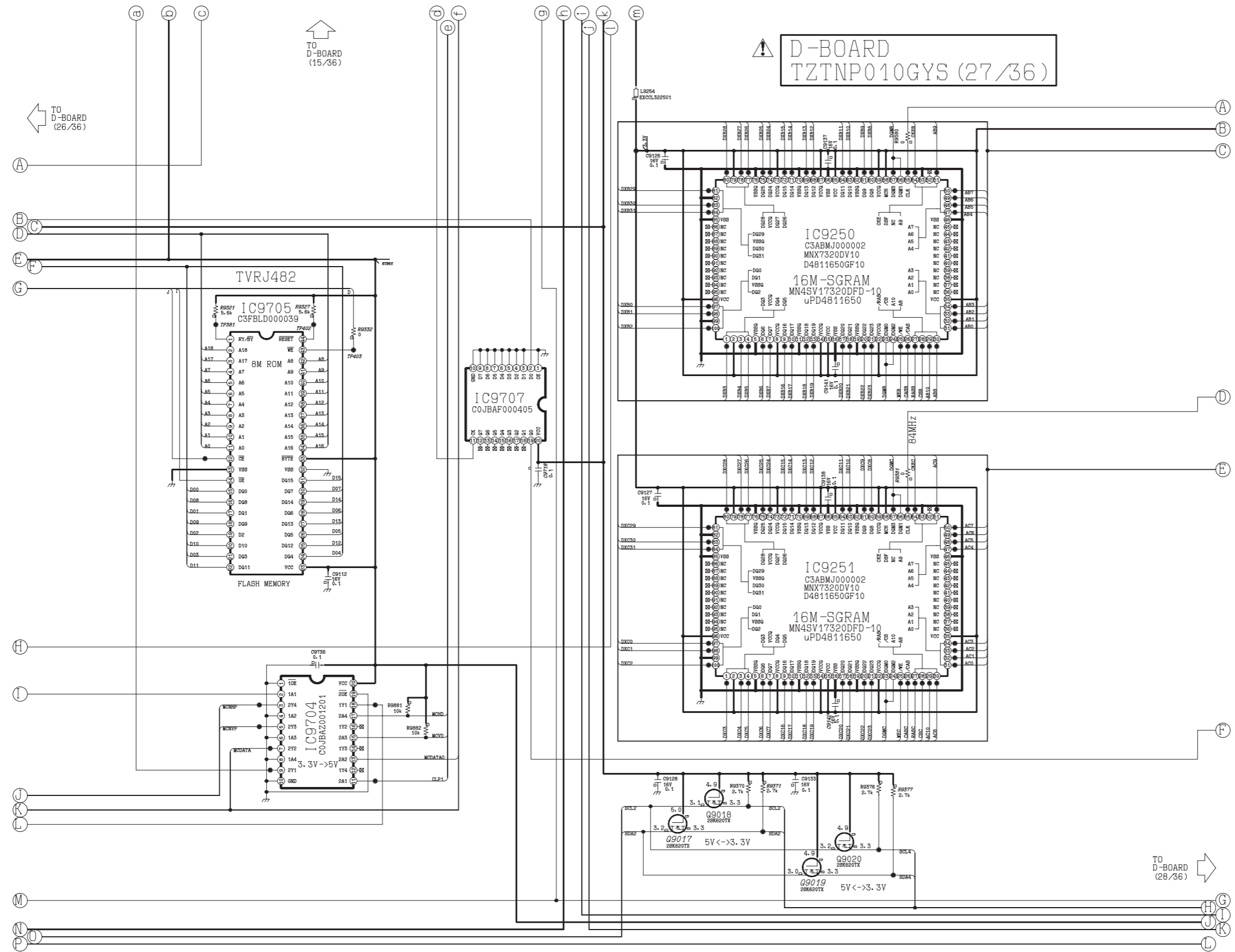

15

16

17

18

19

20

21

# 13.53. D-Board (28/36) Schematic Diagram

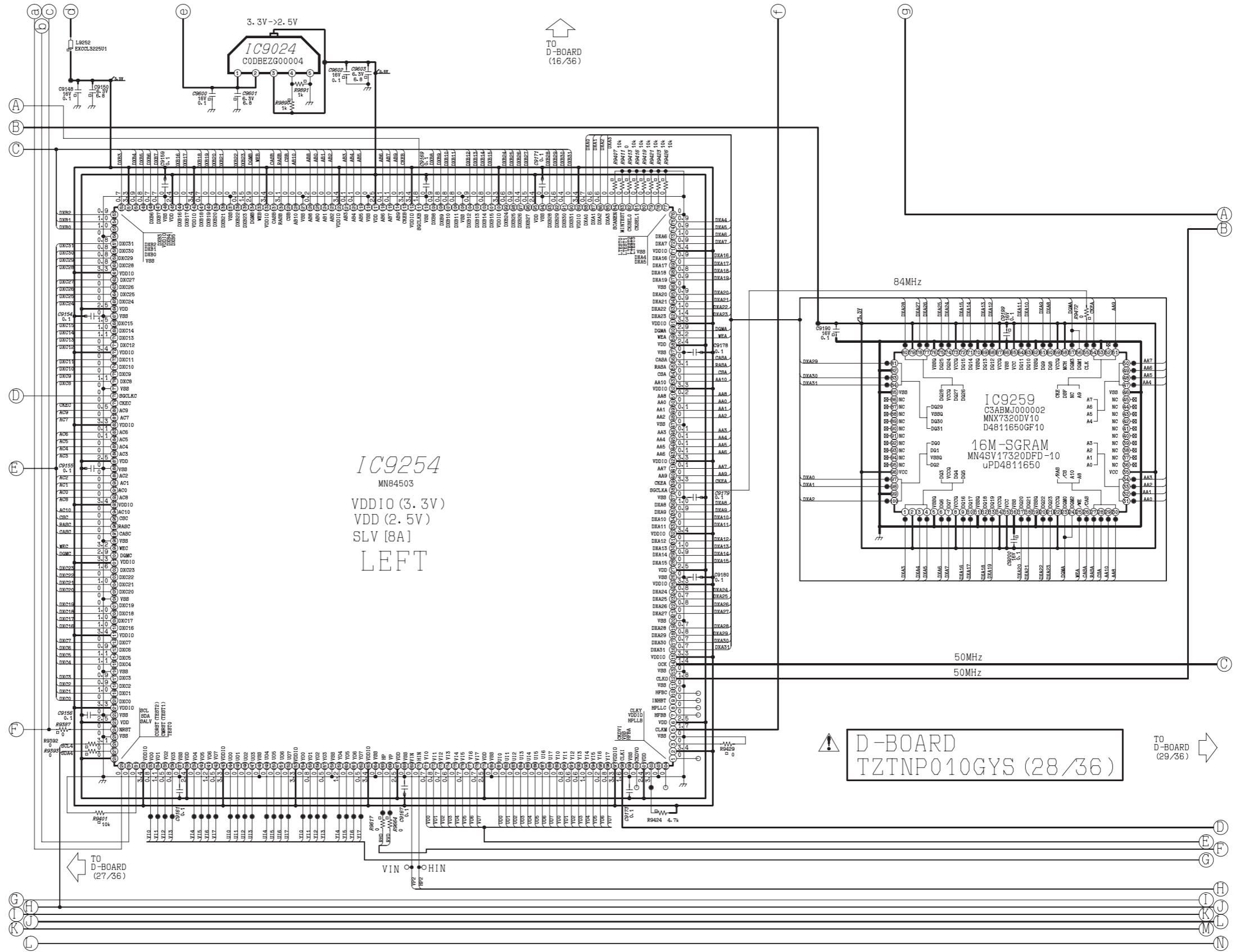





# 13.55. D-Board (30/36) Schematic Diagram

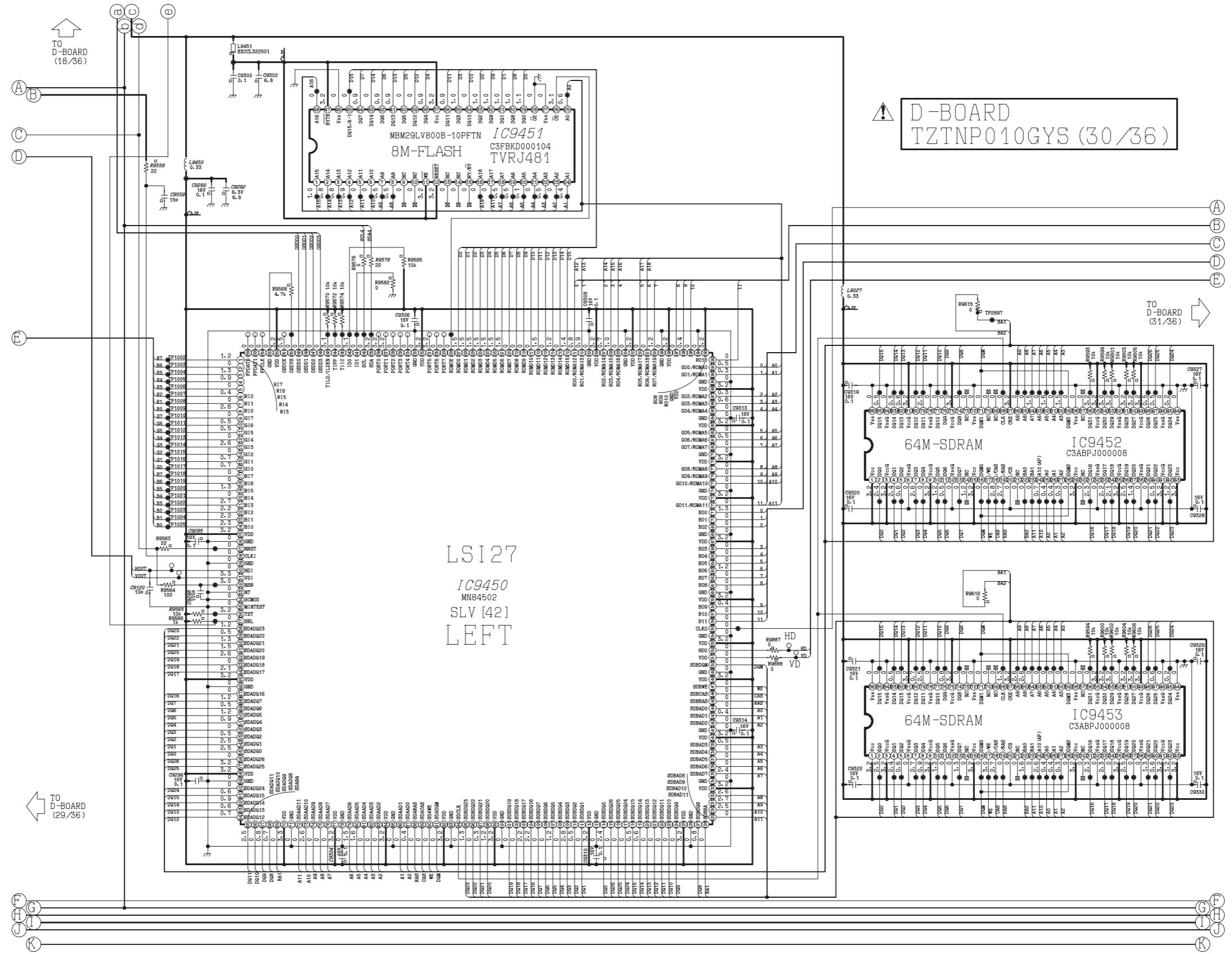

### 13.56. D-Board (31/36) Schematic Diagram

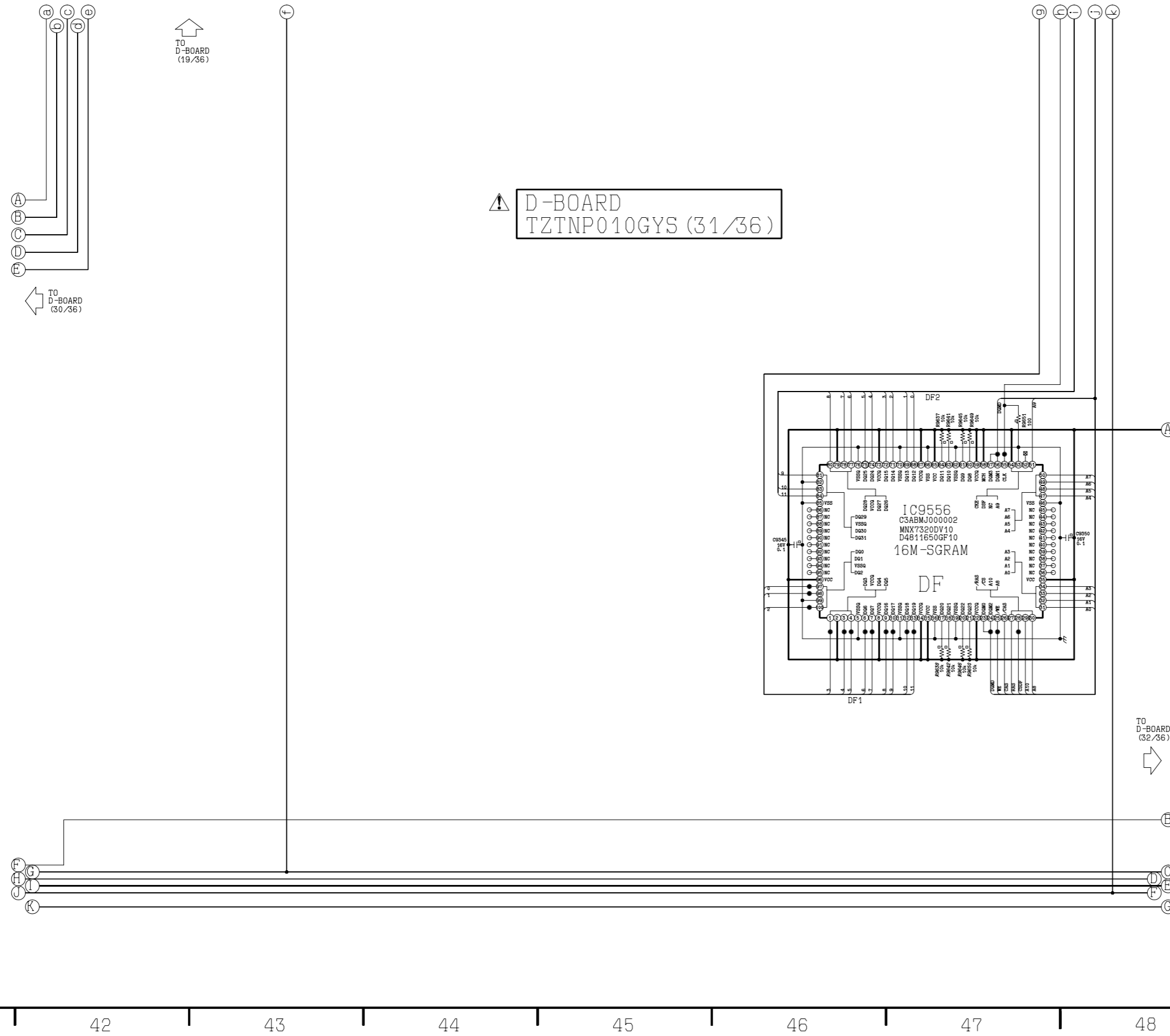

# 13.57. D-Board (32/36) Schematic Diagram

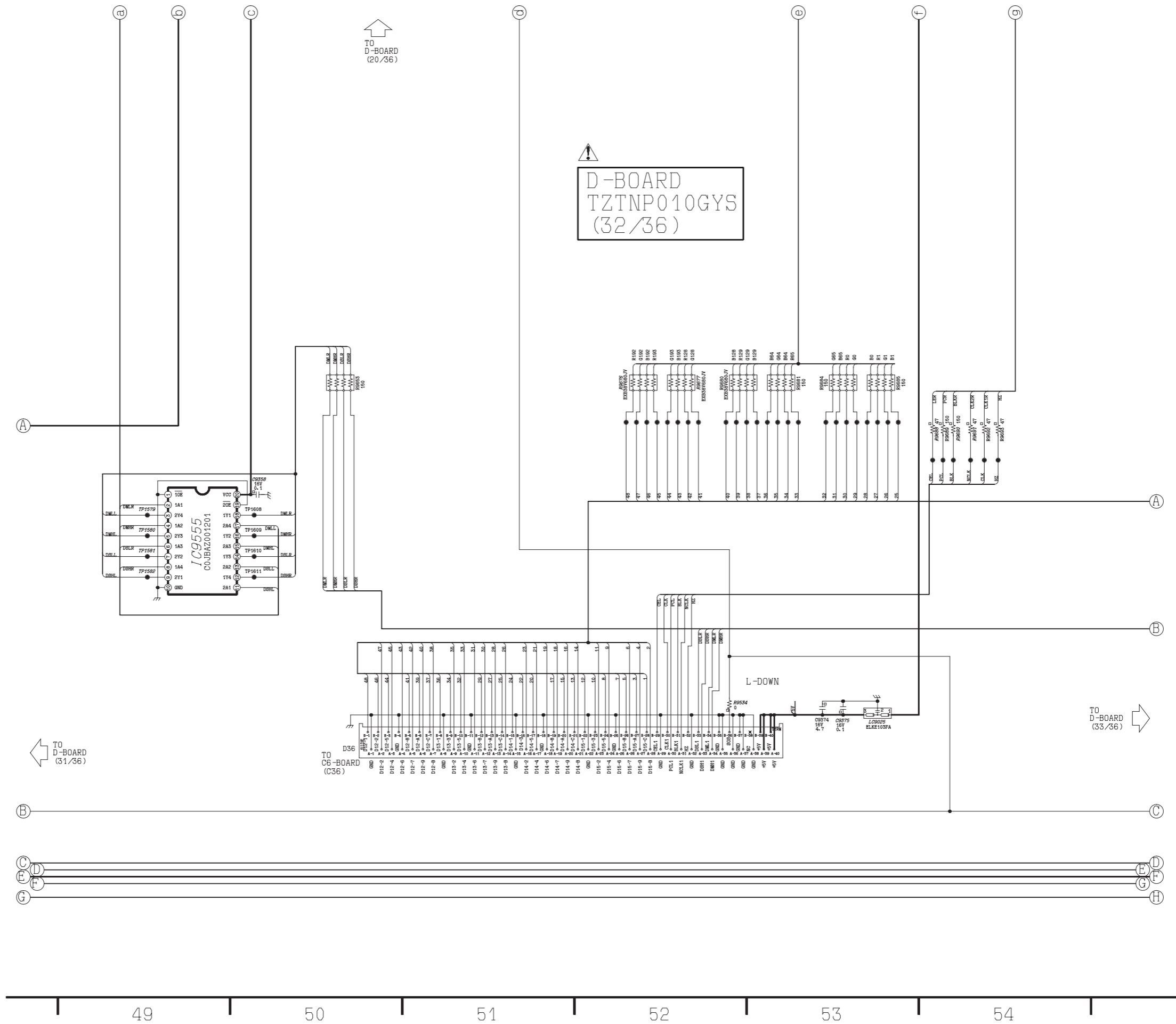

# 13.58. D-Board (33/36) Schematic Diagram

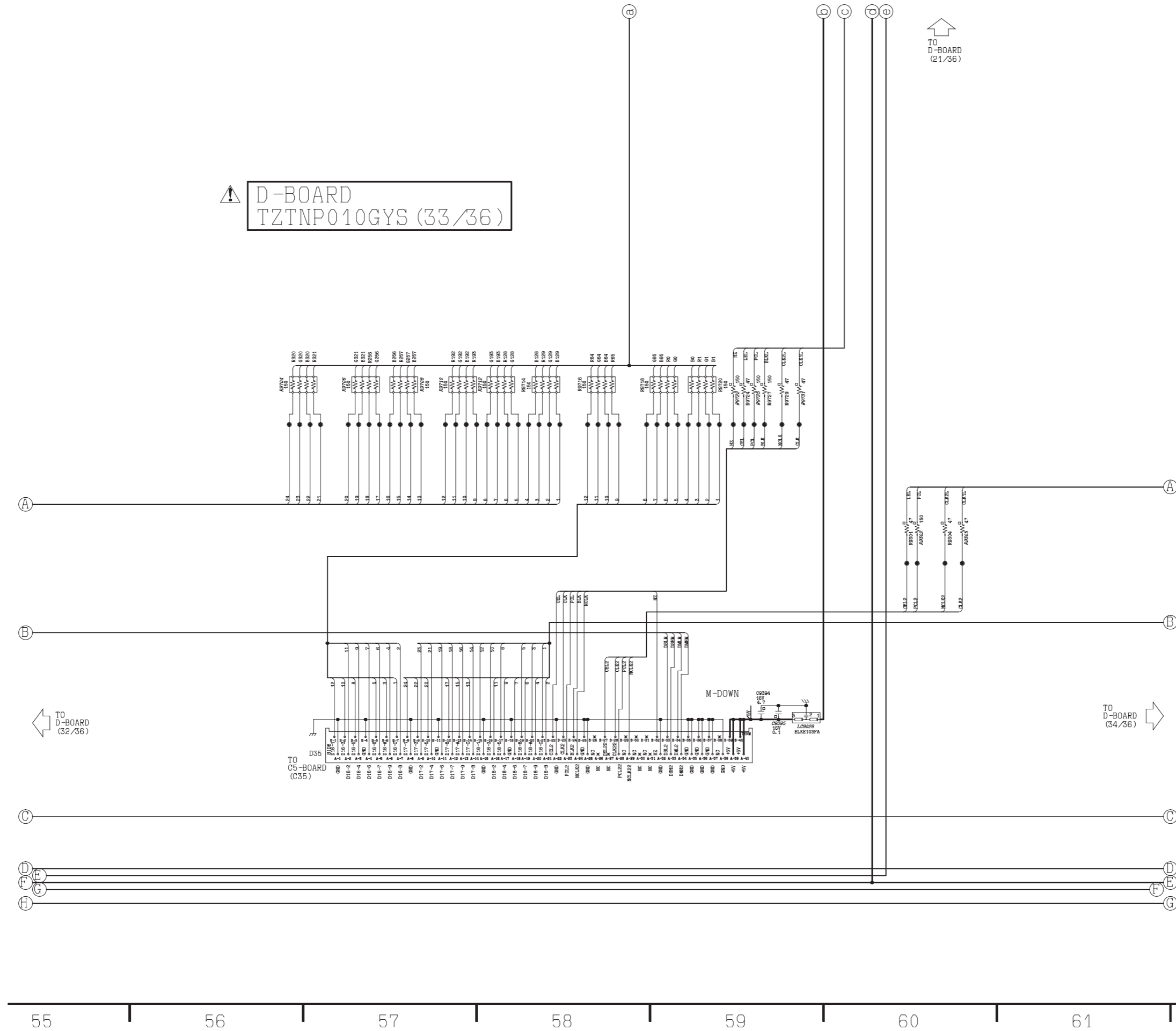

# 13.59. D-Board (34/36) Schematic Diagram

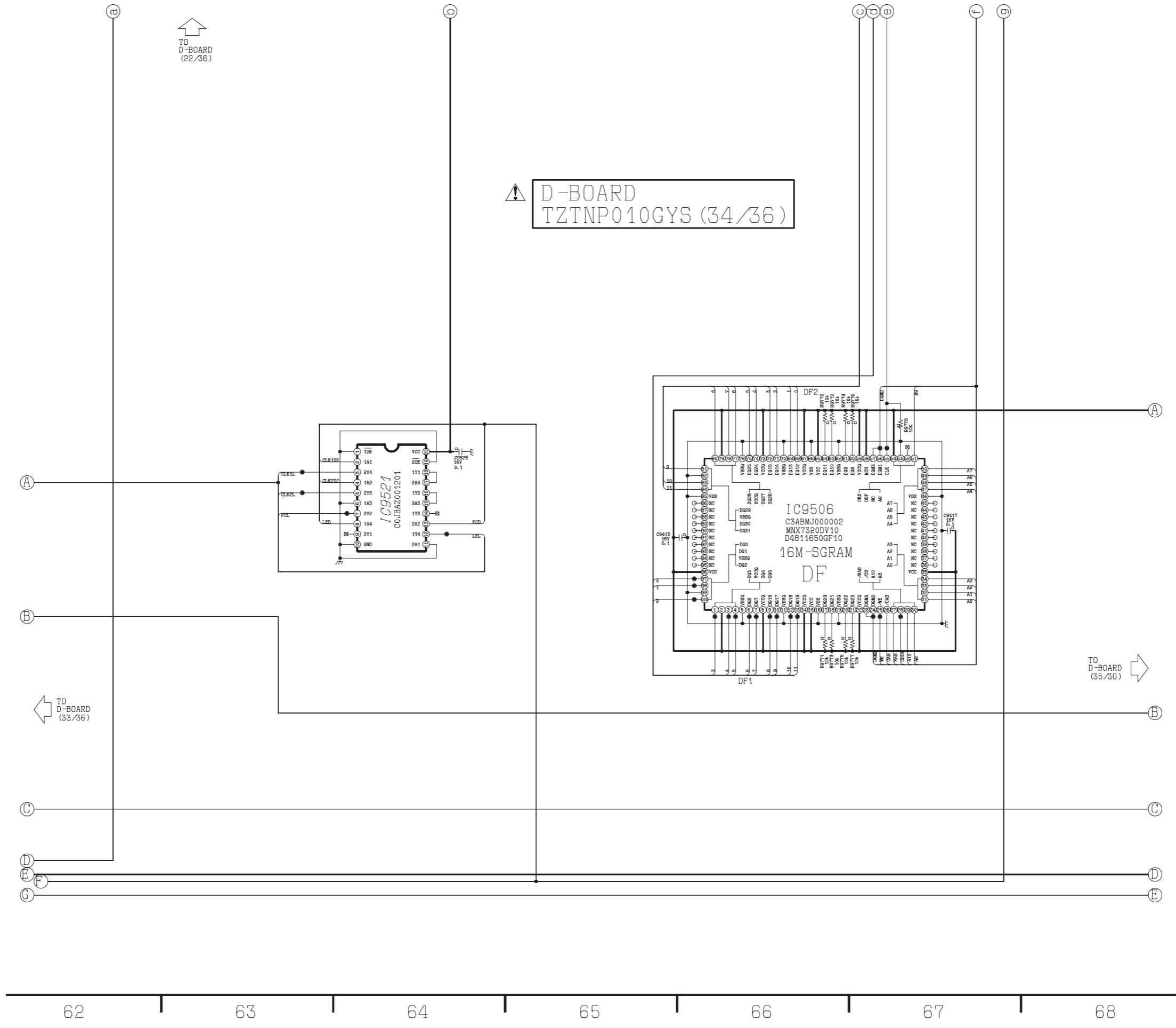

# 13.60. D-Board (35/36) Schematic Diagram

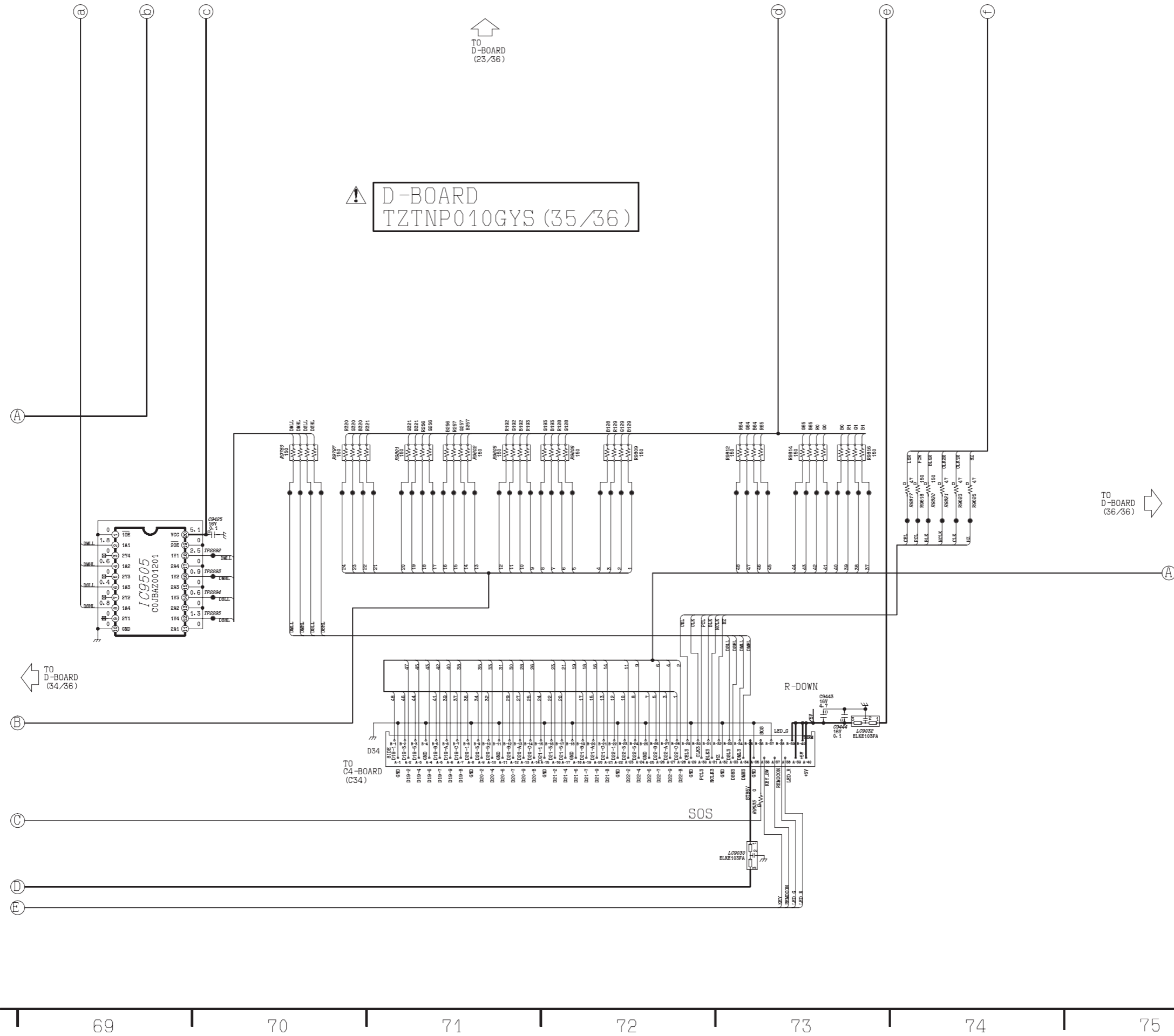

# 13.61. D-Board (36/36) Schematic Diagram

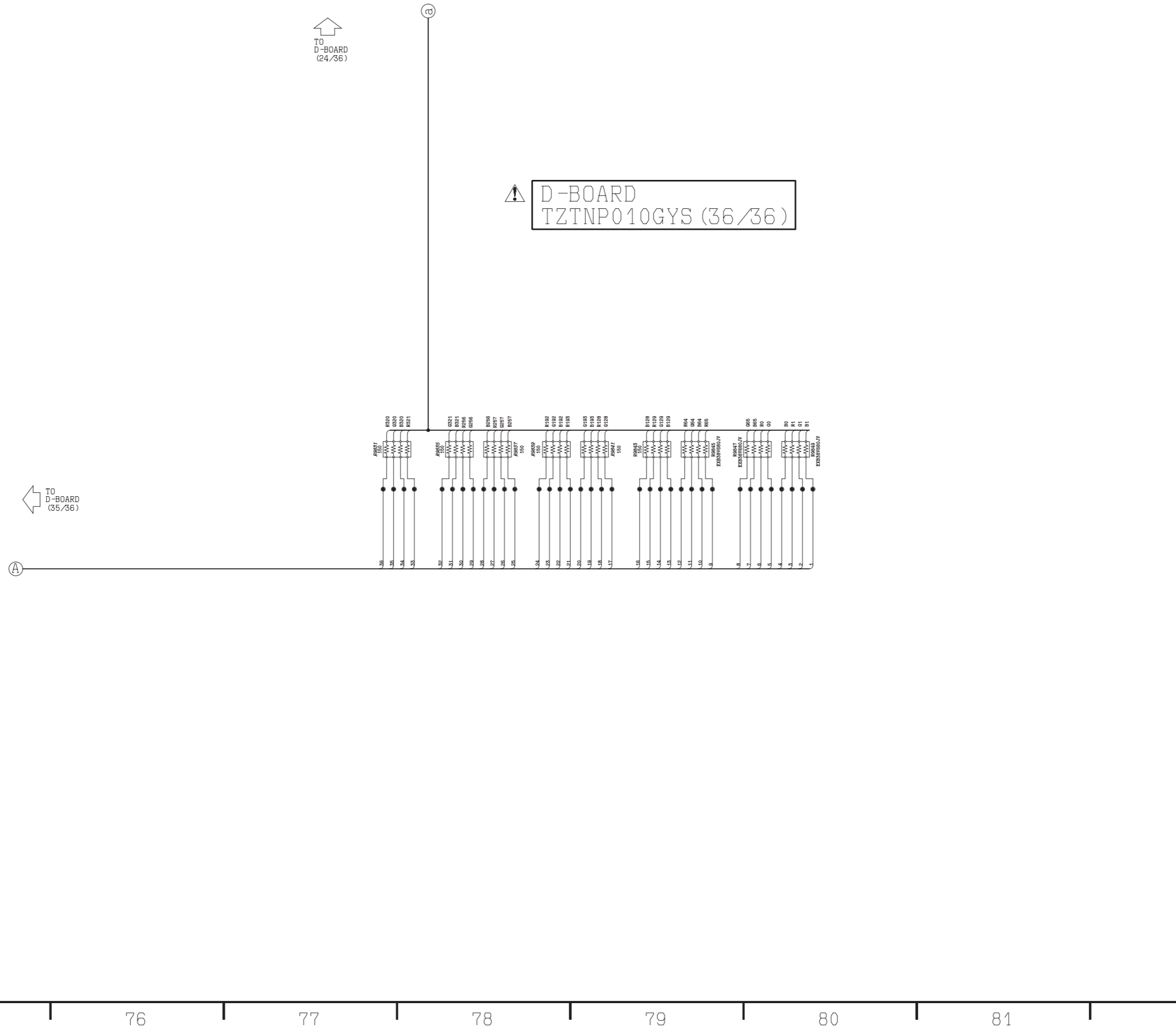

### 13.62. C1, C2, C3, C4, C5, C6, C7 and C8 Board Block Diagram

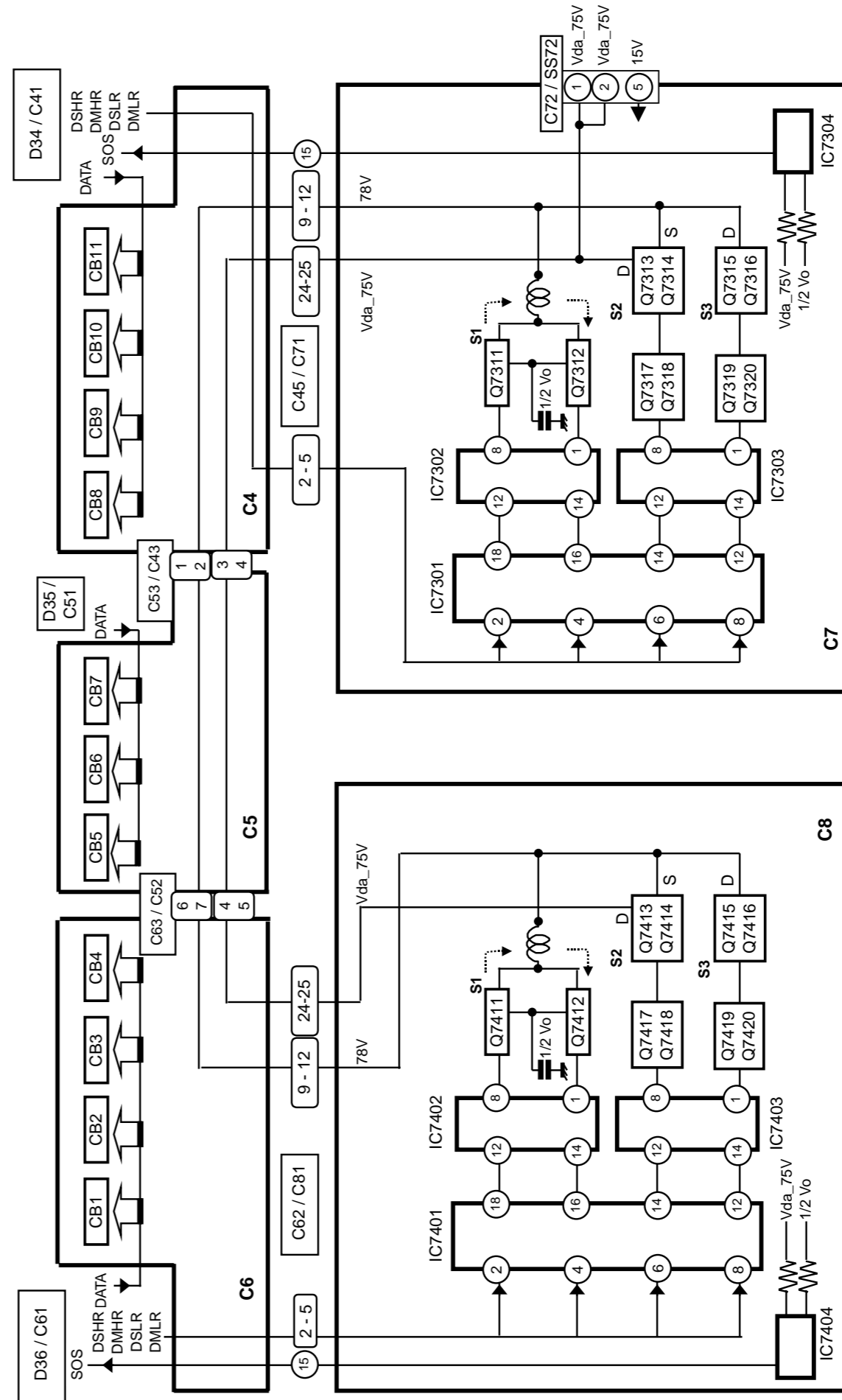
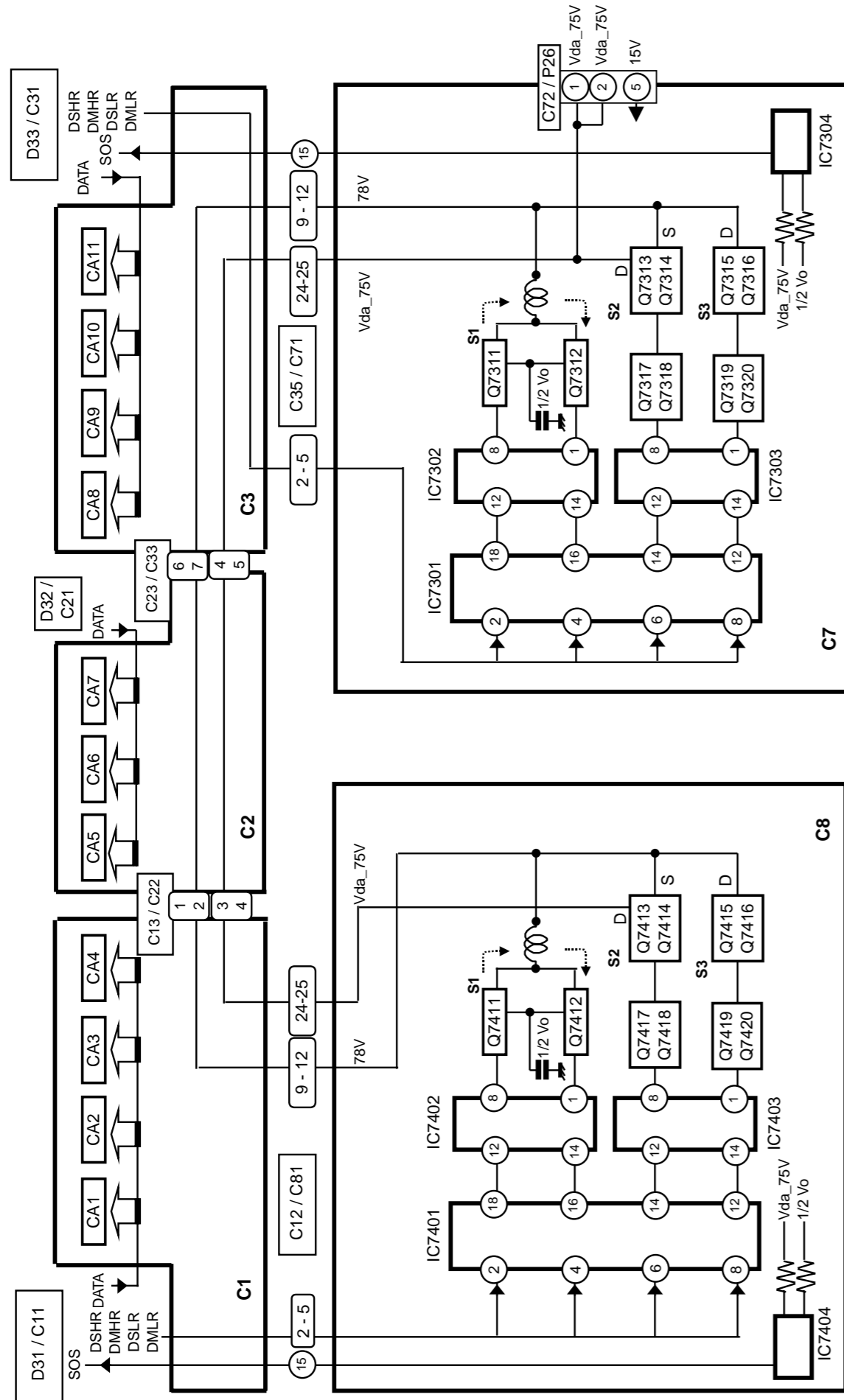



# 13.63. C1-Board Schematic Diagram

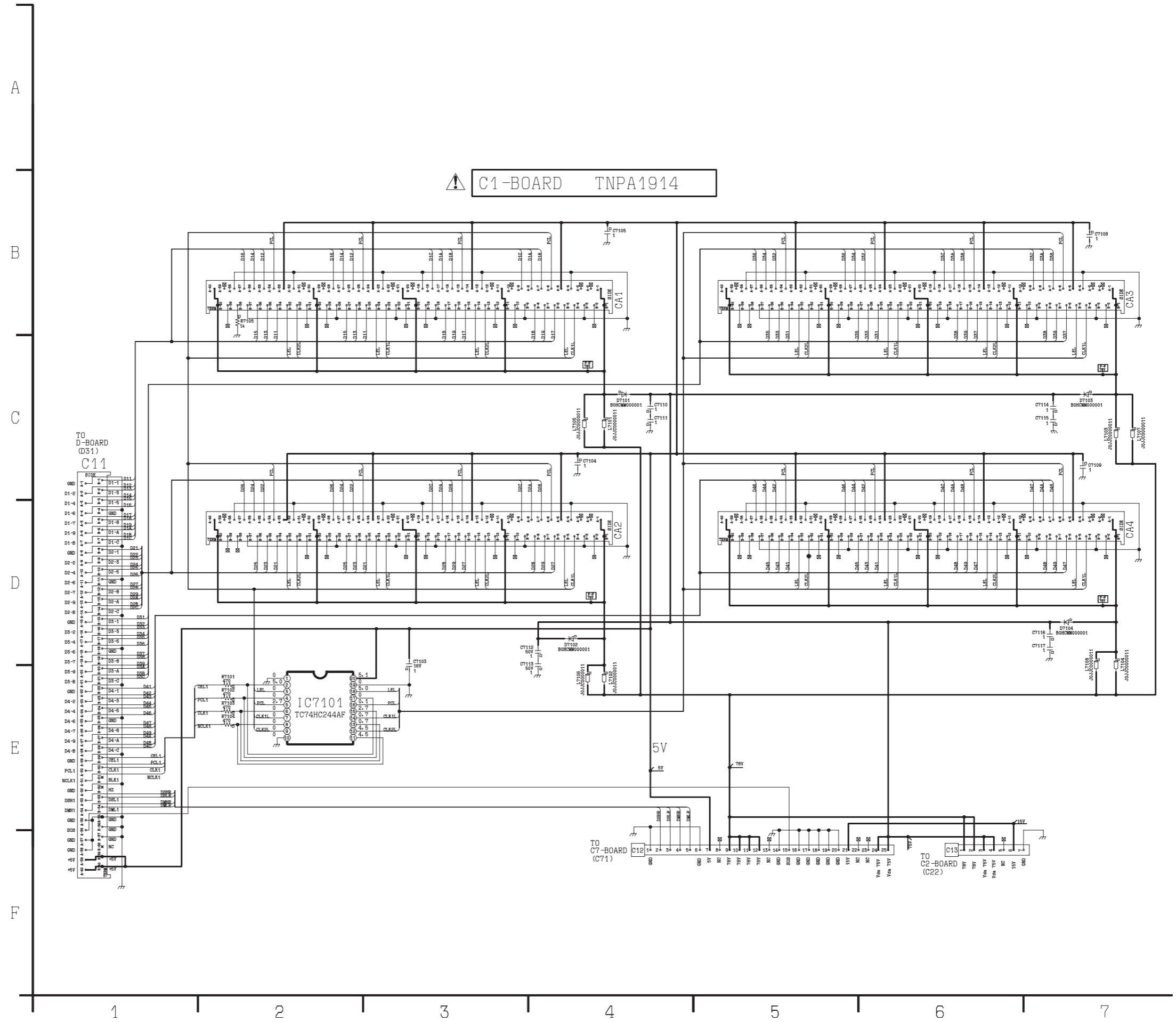

# 13.64. C2-Board Schematic Diagram

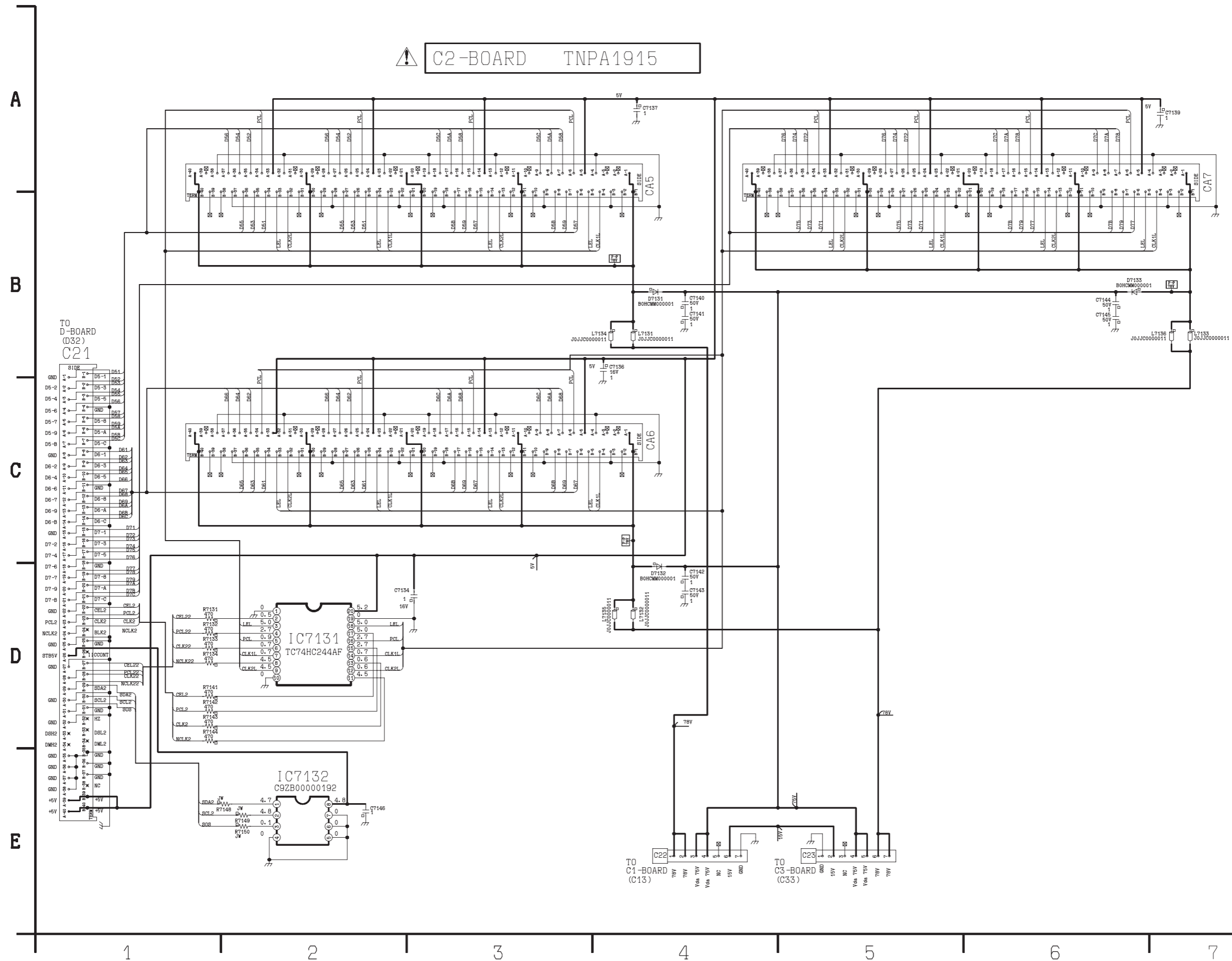

# 13.65. C3-Board Schematic Diagram

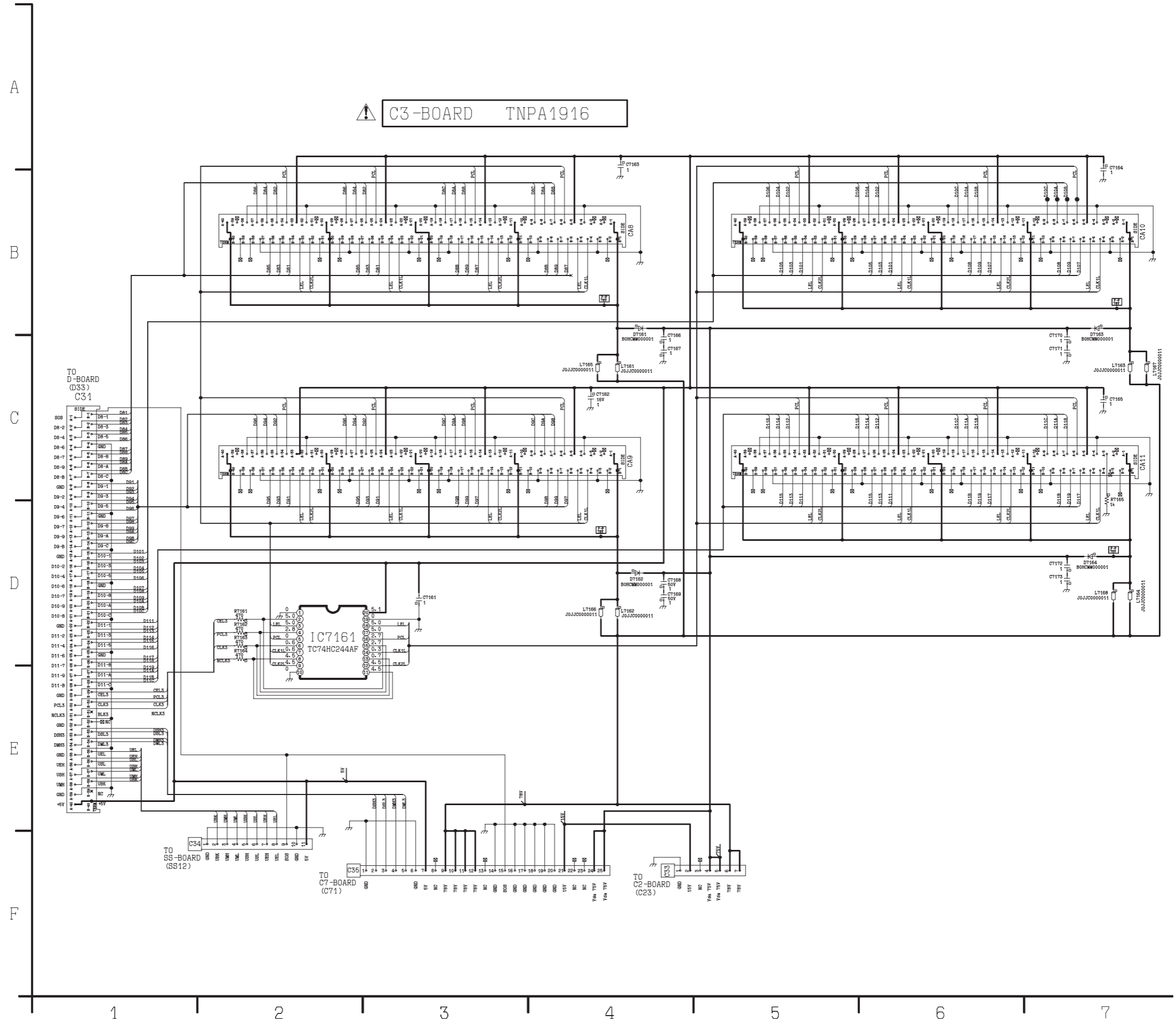

# 13.66. C4-Board and V1-Board Schematic Diagram

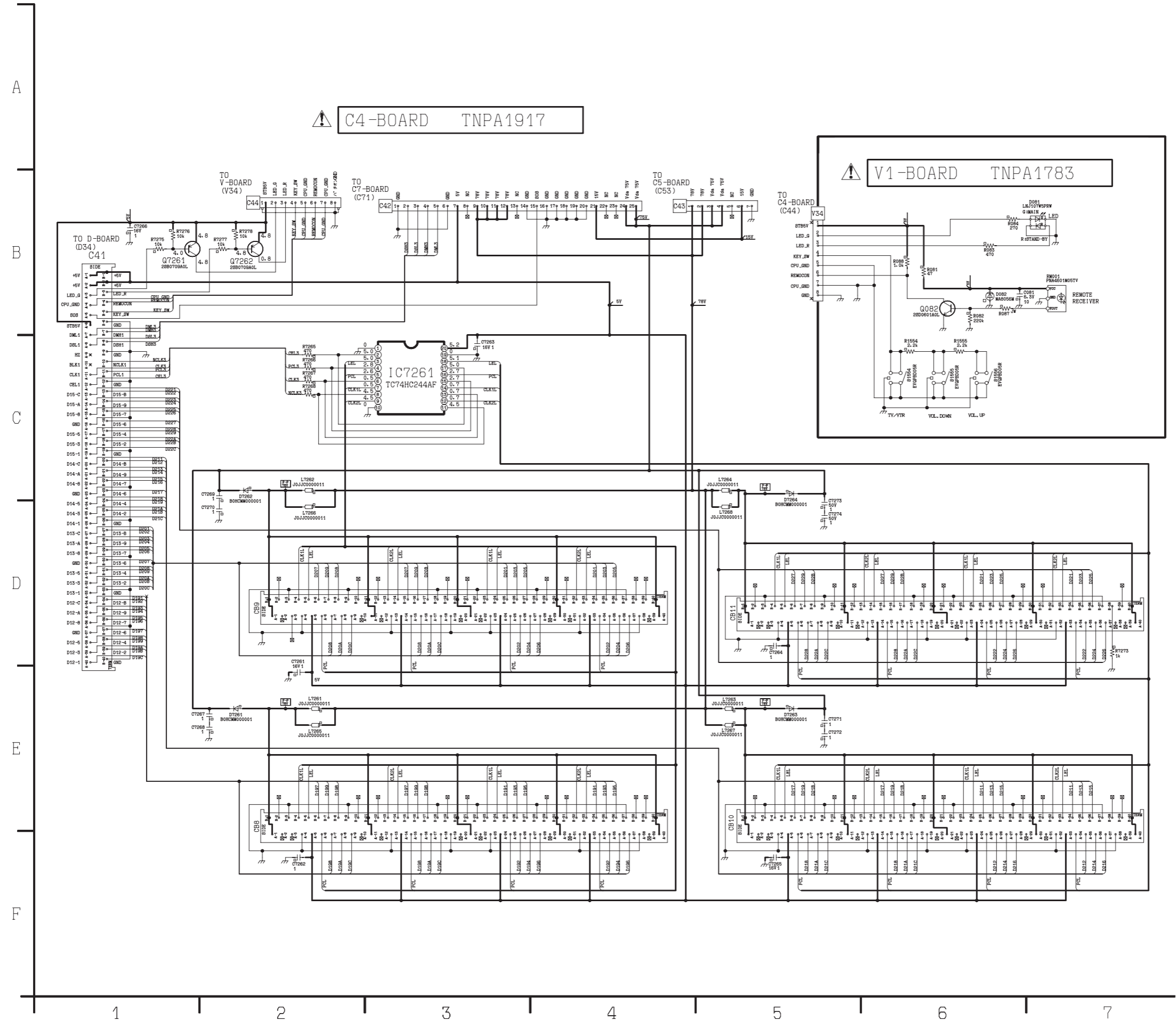

# 13.67. C5-Board Schematic Diagram

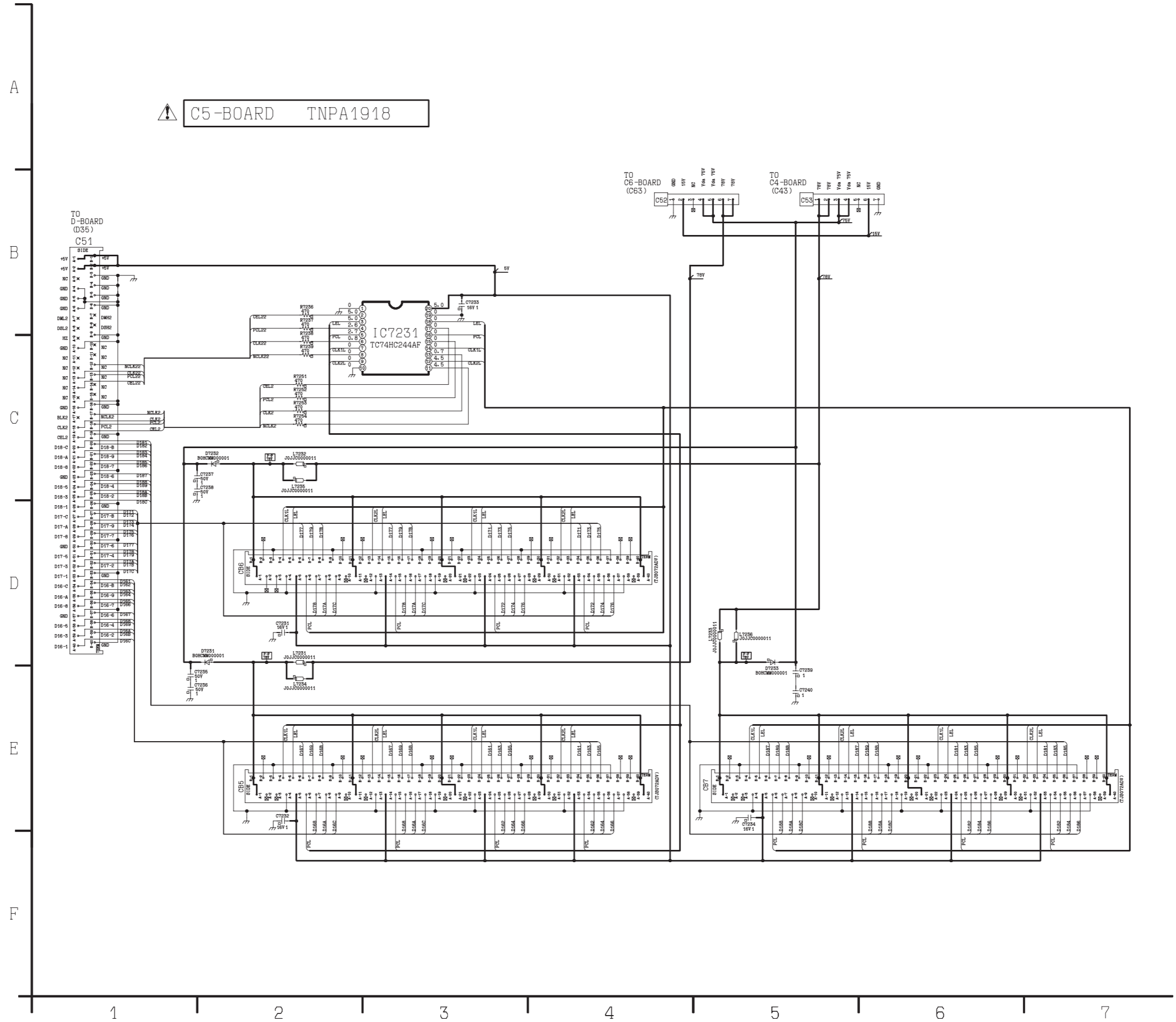



# 13.69. C7-Board Schematic Diagram

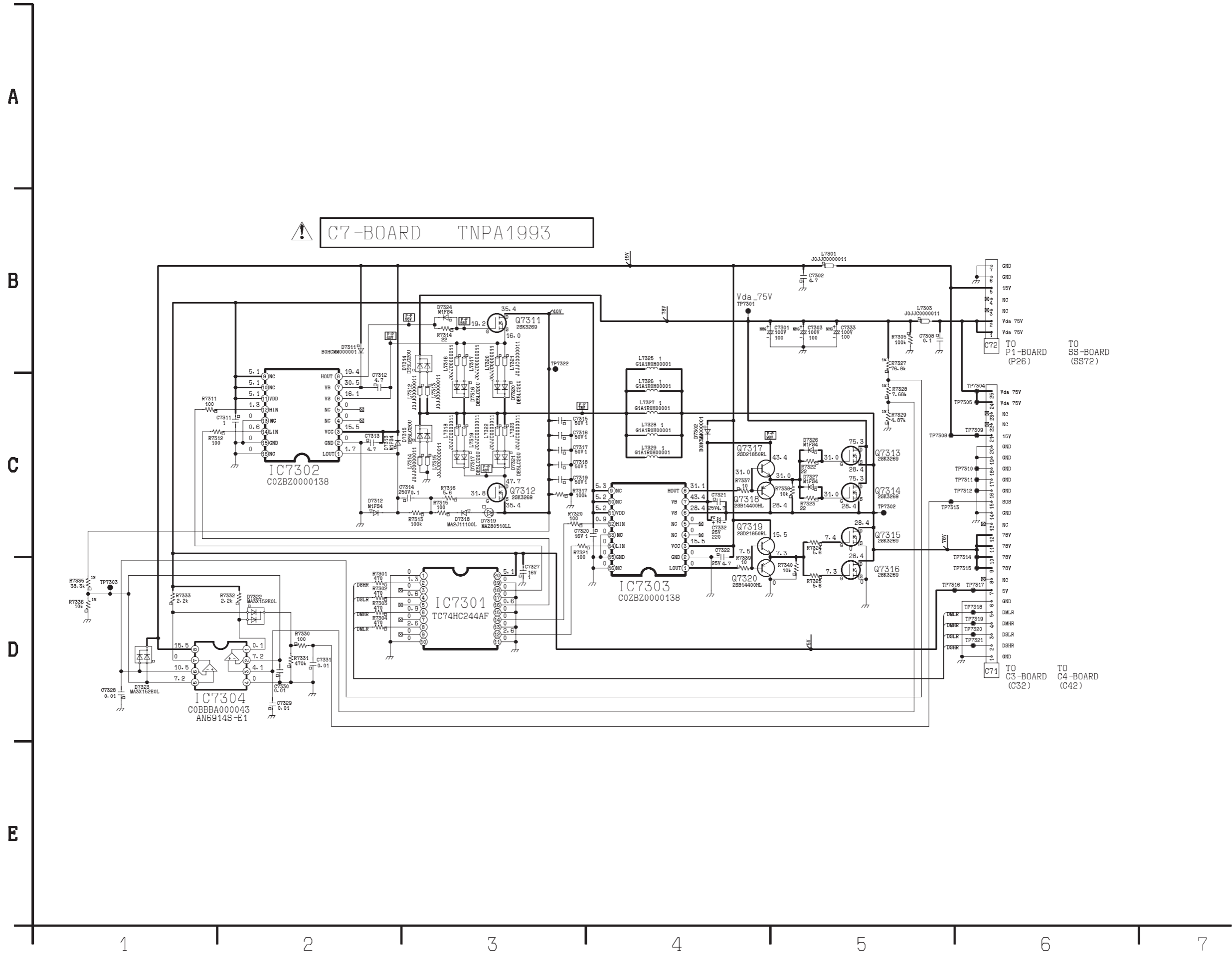

# 13.70. C8-Board Schematic Diagram

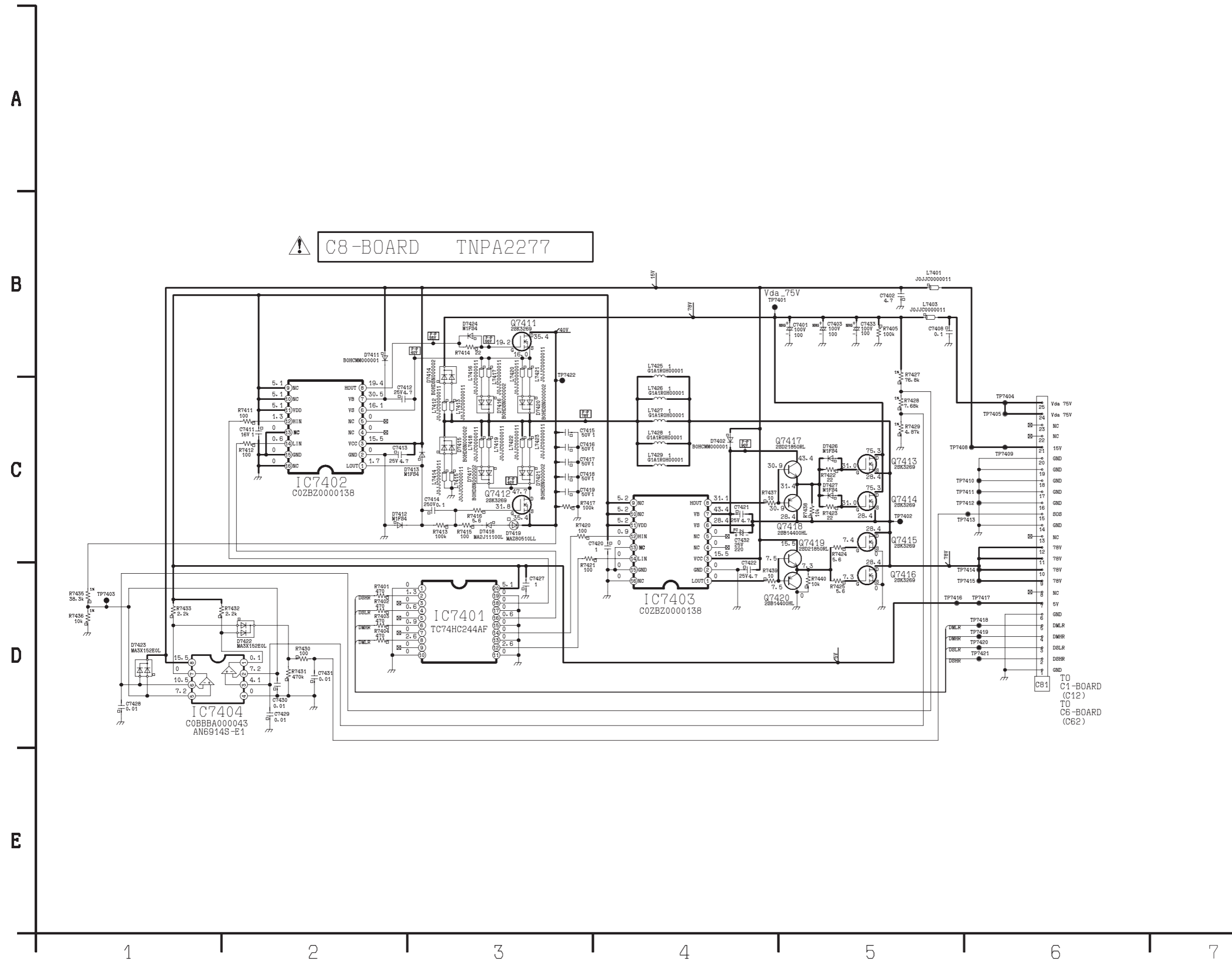



### 13.71. SC-Board Block Diagram

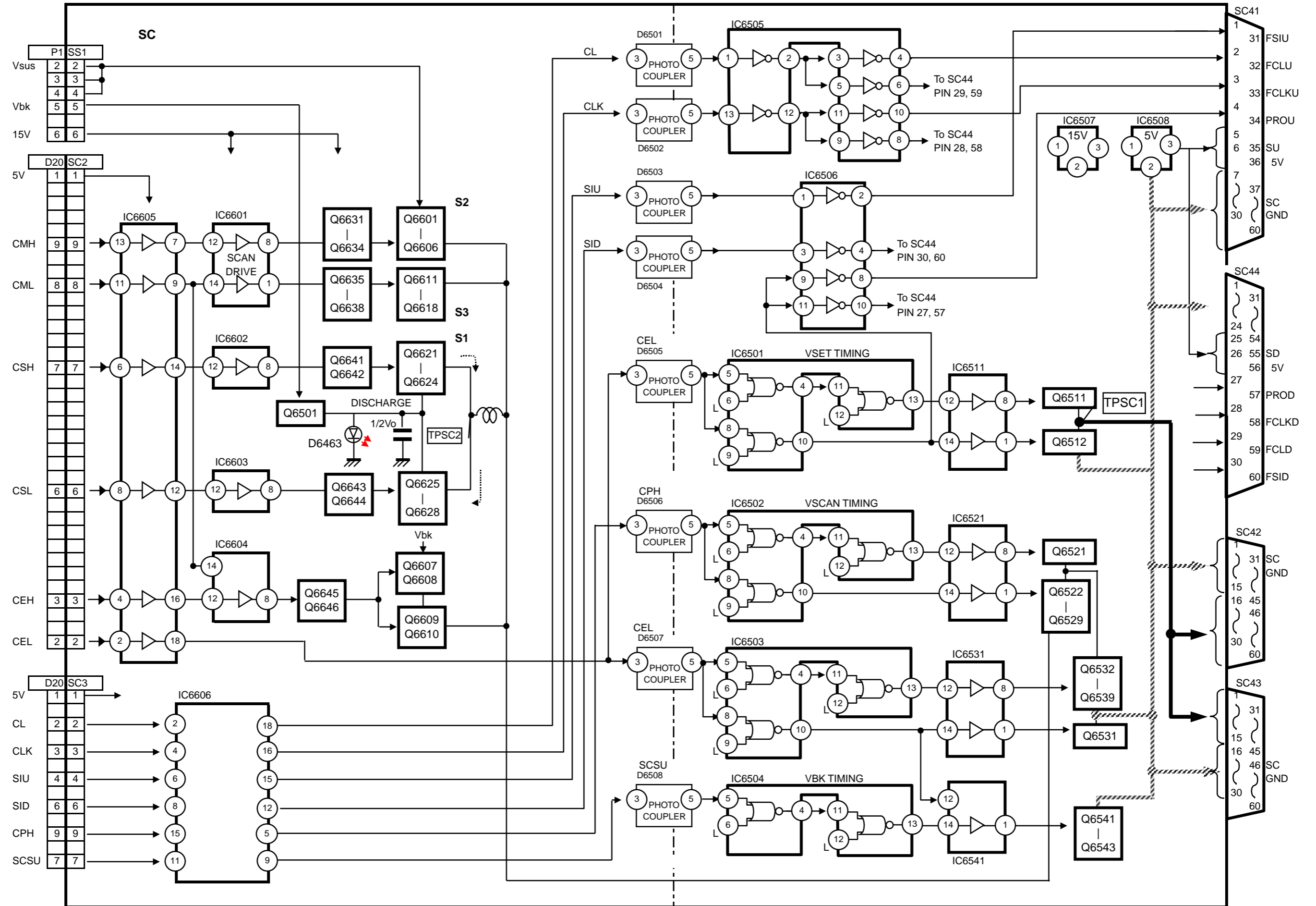

# 13.72. SC-Board (1/2) Schematic Diagram

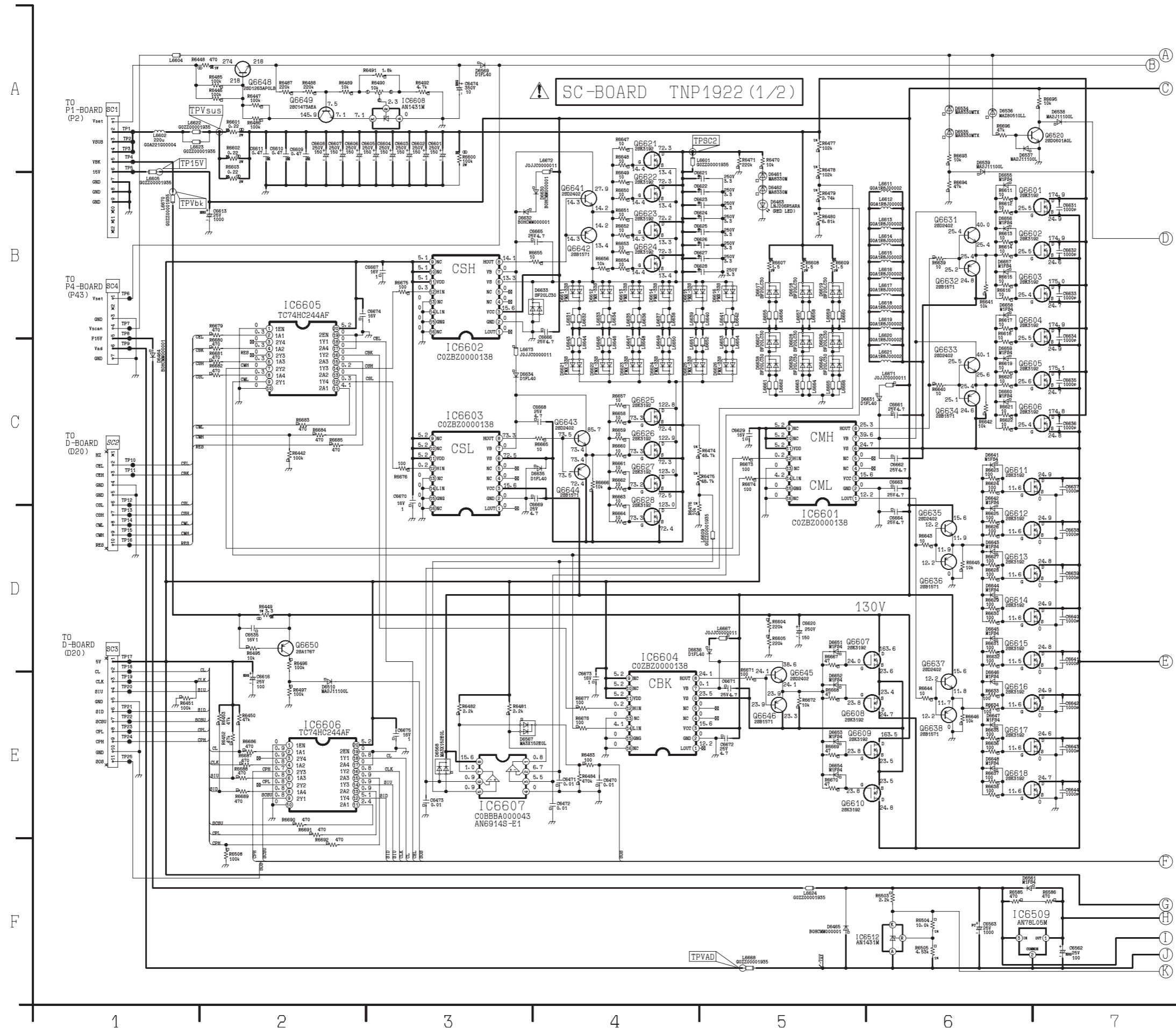



# 13.74. SD-Board (1/2) Schematic Diagram

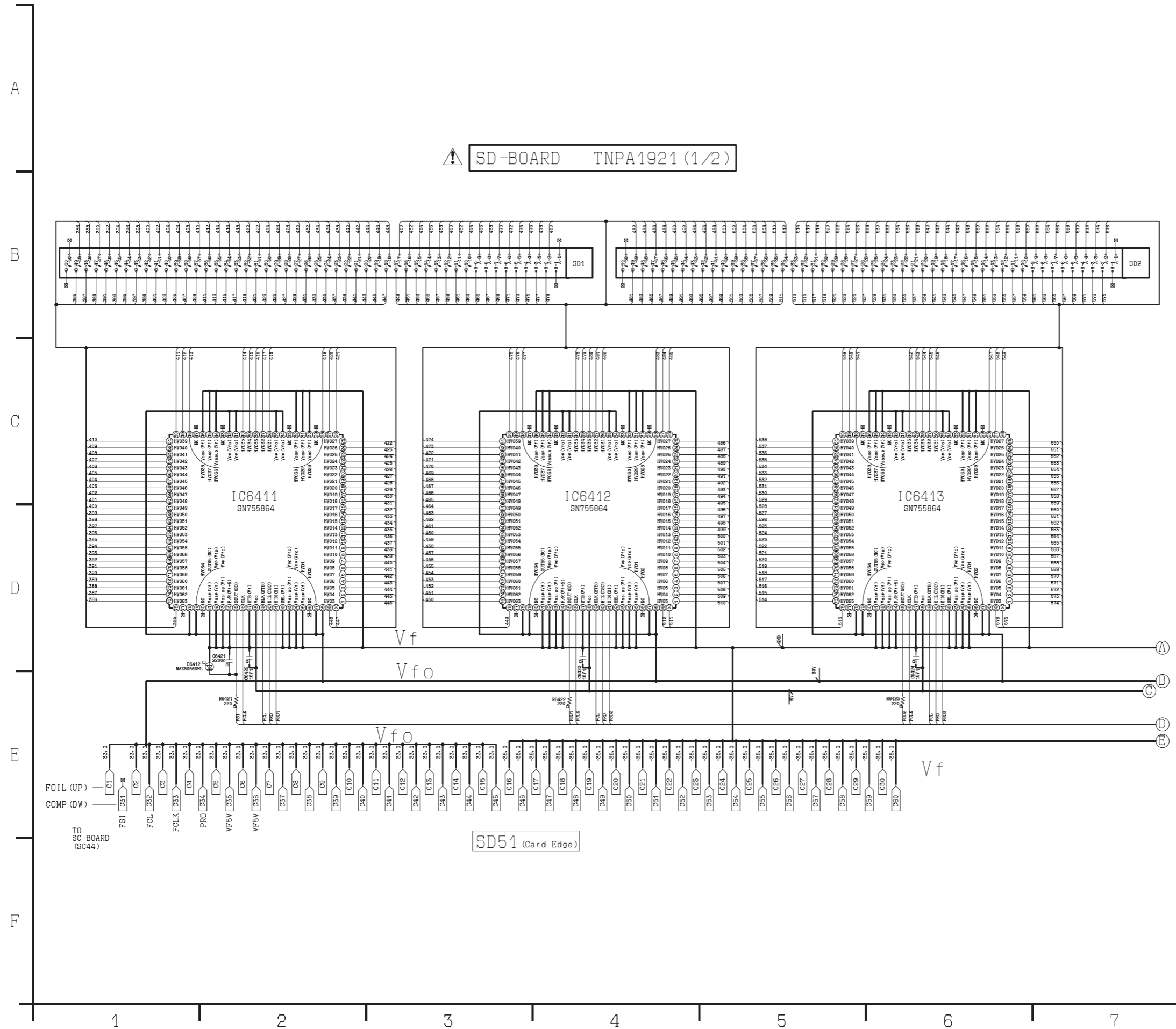

# 13.75. SD-Board (2/2) Schematic Diagram

SD-BOARD TNPA1921 (2/2)

DOWN

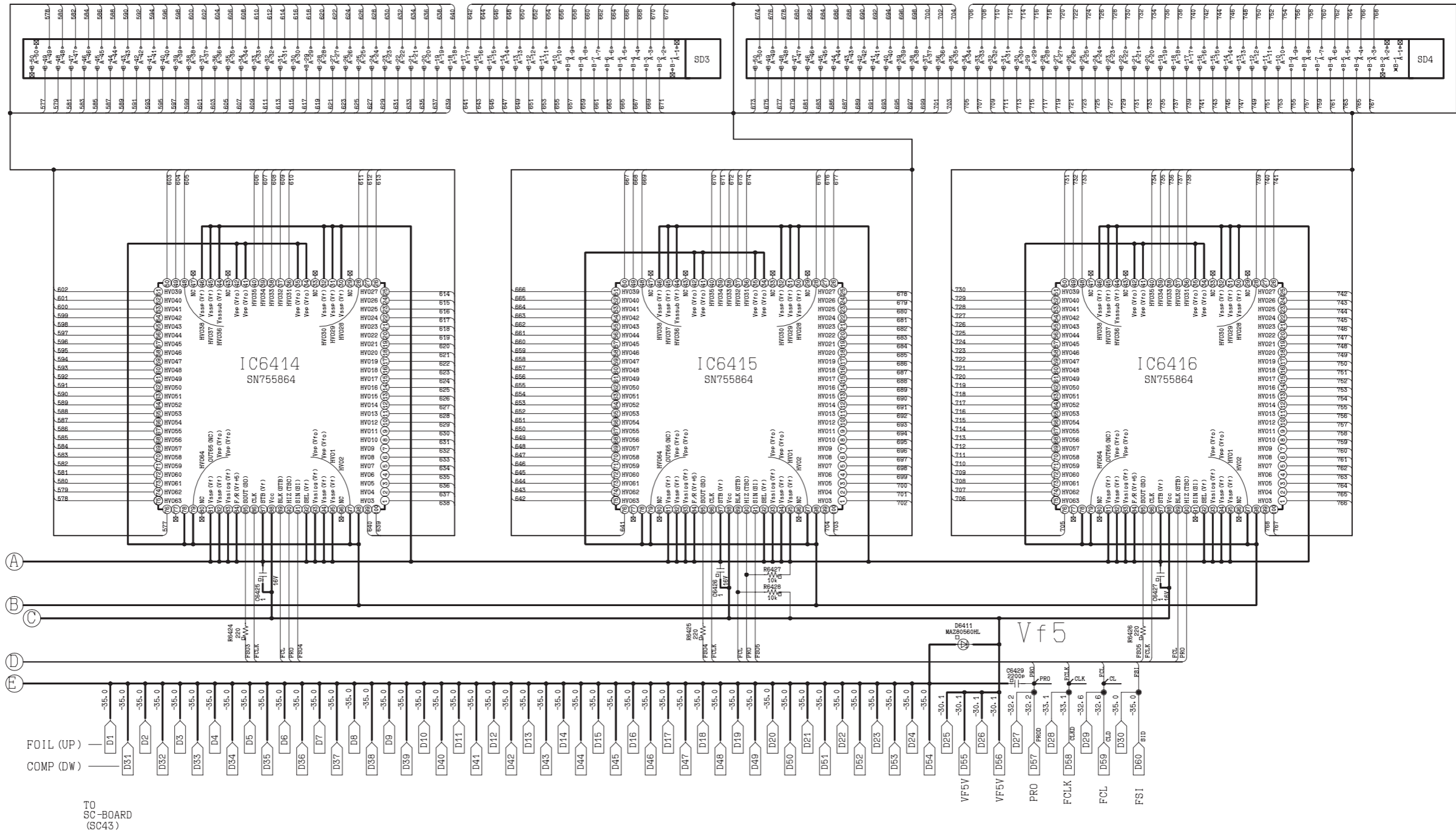

SD52 (Card Edge)

# 13.76. SU-Board (1/2) Schematic Diagram

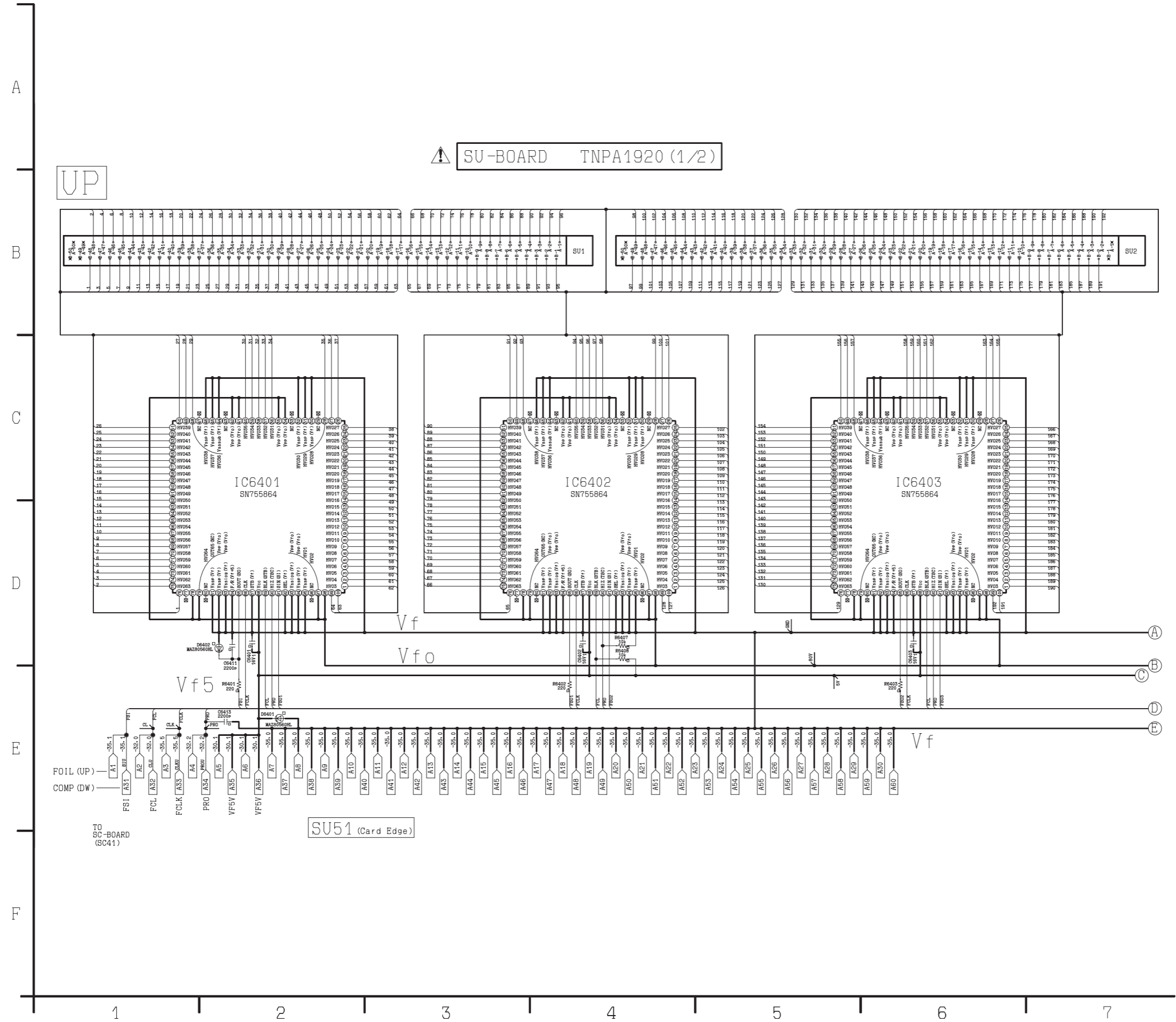



### 13.78. SS, SS2 amd SS3 Board Block

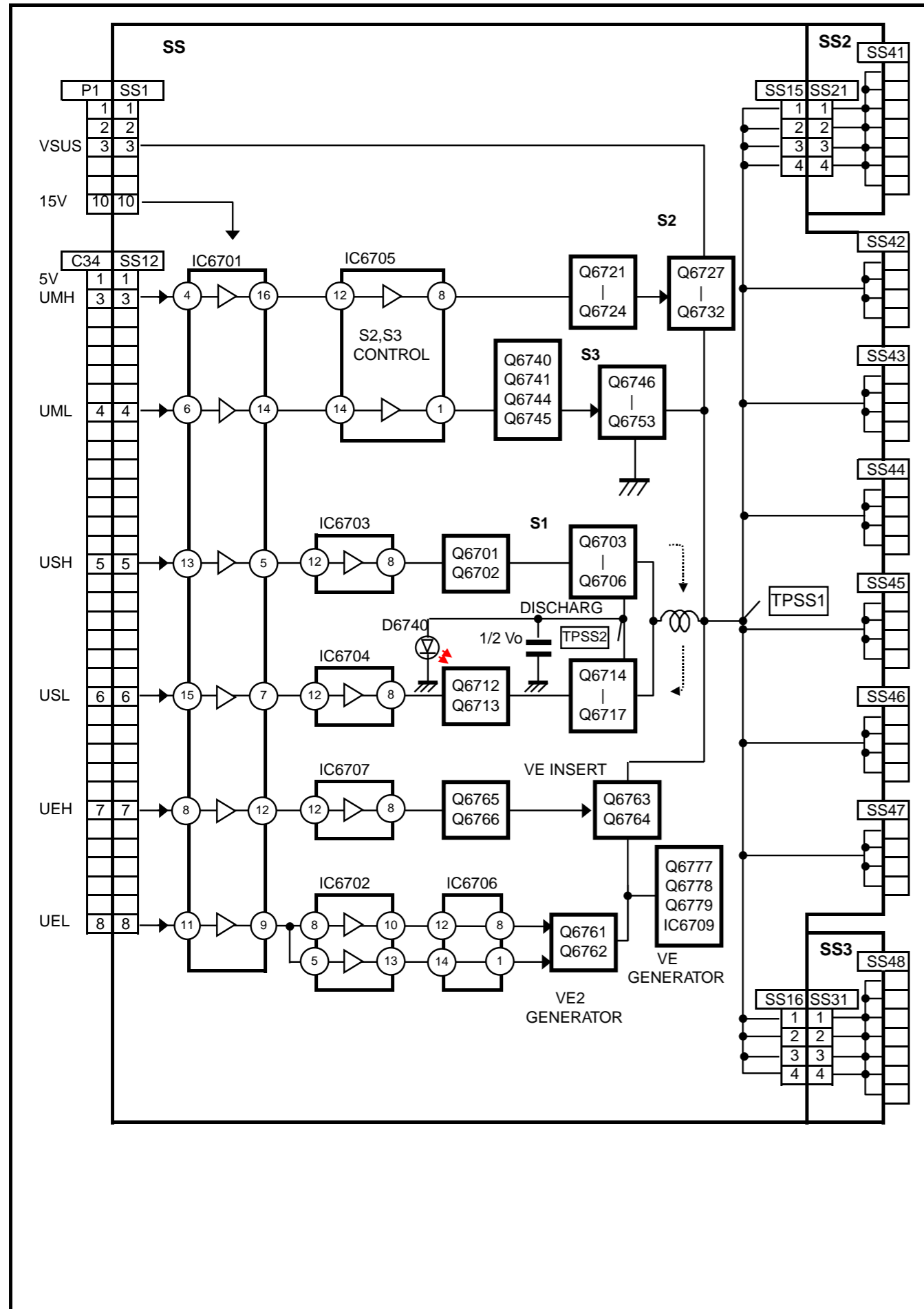



# 13.79. SS-Board (1/2) Schematic Diagram

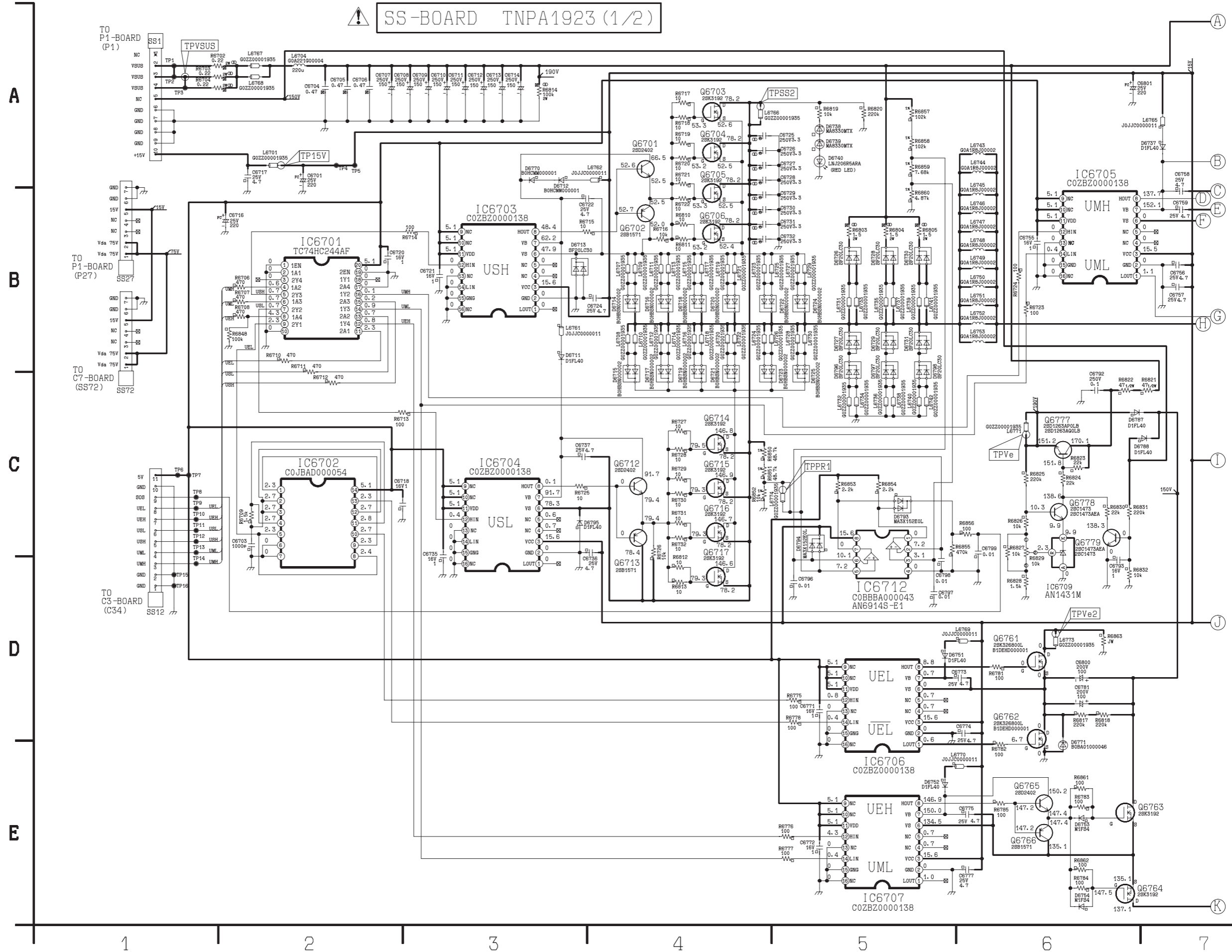

### 13.80. SS-Board (2/2) SS2-Board, SS3-Board and S1-Board Schematic Diagram

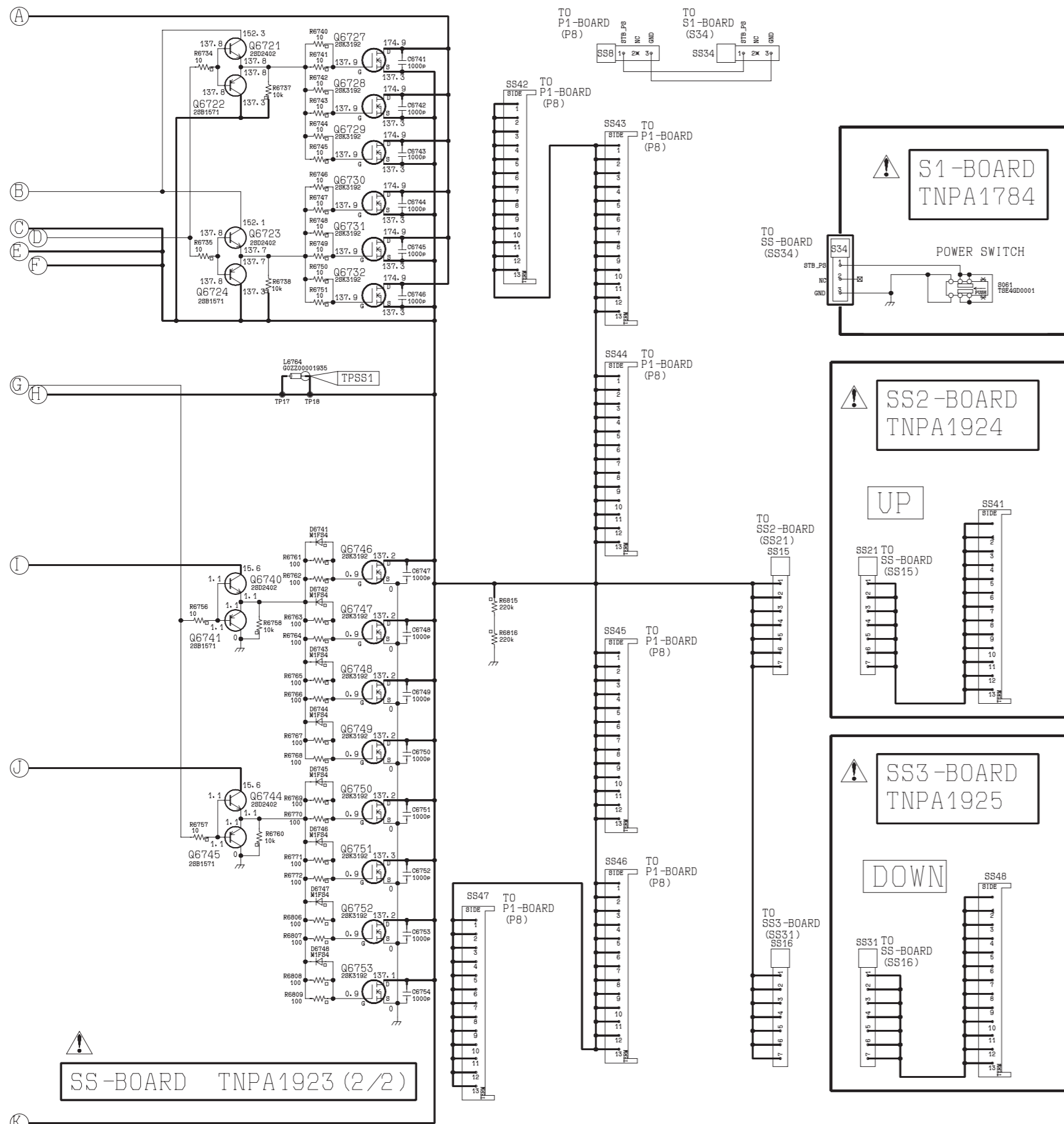

7 8 9 10 11 12 13

If you need more information on Computer and Electronic Repair, please visit these websites to improve yourself.

<http://www.fastrepairguide.com>

<http://www.protech2u.com>

<http://www.plasma-television-repair.com>

<http://www.lcd-television-repair.com>

Happy Repairing!!

### **Highly Recommended Repair Ebook:**

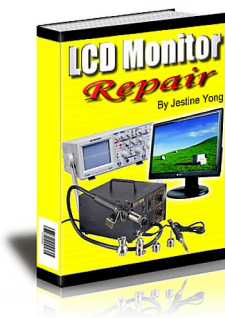

If you're a LCD Monitor repairer, then this is the best guide for you. Why? Because, the author revealed all his LCD Monitor Repairing secrets for you. I think, with just few Repair tips you learned from this guide you will get back your investment!

[Click Here to read](#) more.



This eBook will show you how to test the electronic component correctly and accurately. Some of you may say that I don't need this eBook because it is too simple! Do you know that, in fact there is lots of testing electronic components secrets I have learned from this guide? Do you know how to test a 'TRIAC' correctly and accurately? If you answer no then I guess you have to get this eBook. [Click Here to read more.](#)

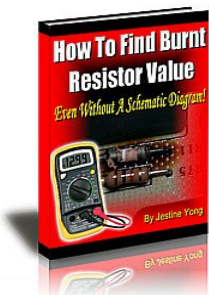

Are you tired of searching the service manuals to look for the value of a burnt resistor? If the answer is YES, then this eBook is a 'must have' guide for you. You can save a lot of time and be able to repair customer's Electronic equipment with burnt resistors in it.

[Click here to read more.](#)